

XPC PIN CLAMPS & XFC HOOK CLAMPS

Proven locking pin clamp in a new cost saving design

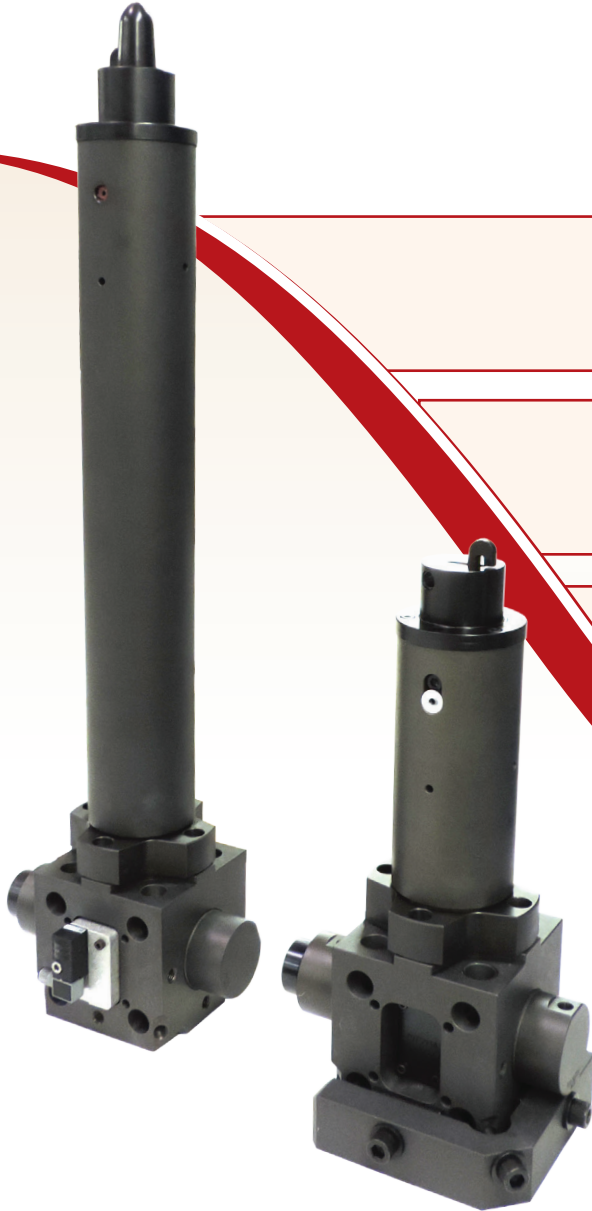

Enhanced locking pin clamp for airless transfer pallets

Easy pin location adjustment using the XYZ shim box

Built in pin riser for improved weld gun access

3mm locking range

See the BTM Pin & Hook Clamp Line of Products

www.btmcomp.com/pin-and-hook-products.html



BTM[®]
COMPANY

www.btmcomp.com

810-364-4567



SAFETY NOTE

Customer is responsible for the safe operation and use of the products shown in this literature.

HOW BTM XPC LOCKING PIN CLAMPS WORK



STEP ONE

With the clamp finger retracted, the part is loaded over the locating pin.



STEP TWO

The material rests on the clamp Rest Block ("Donut")

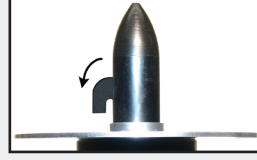

STEP THREE

The finger swings out of the locating pin over the first 5mm of travel.

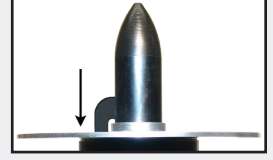

STEP FOUR

The finger then has up to 10mm of straight line travel to the clamped position. The last 3mm is locking range for a BTM locking pin clamp. (No adjustments required.)

TABLE OF CONTENTS

Overview **3**

Advantages **4-5**

Components **5**



XPC Clamp Specifications **6**

XPC Clamp How to Order **6**

XPC Clamp Ordering Options **7**

XPC Clamp Dimensions **8**

XPC Clamp Special Orders **9**



XFC Clamp Specifications **10**

XFC Clamp How to Order **10**

XFC Clamp Ordering Options **11**

XFC Clamp Dimensions **12**

XFC Clamp Special Orders **13**

Shim Box Assembly **14-15**

Warranty Information **Back Cover**

! BTM reserves the right to make changes to its literature without any prior notice. Go to www.btmcomp.com for latest version.

OVERVIEW OF COST SAVINGS

The XYZ Shim Box mount allows easy, accurate and stable adjustment of the pin location during setup or if the pin clamp location is compromised. XPC Pin Clamps can be side or bottom mounted with the XYZ Shim Box mount.

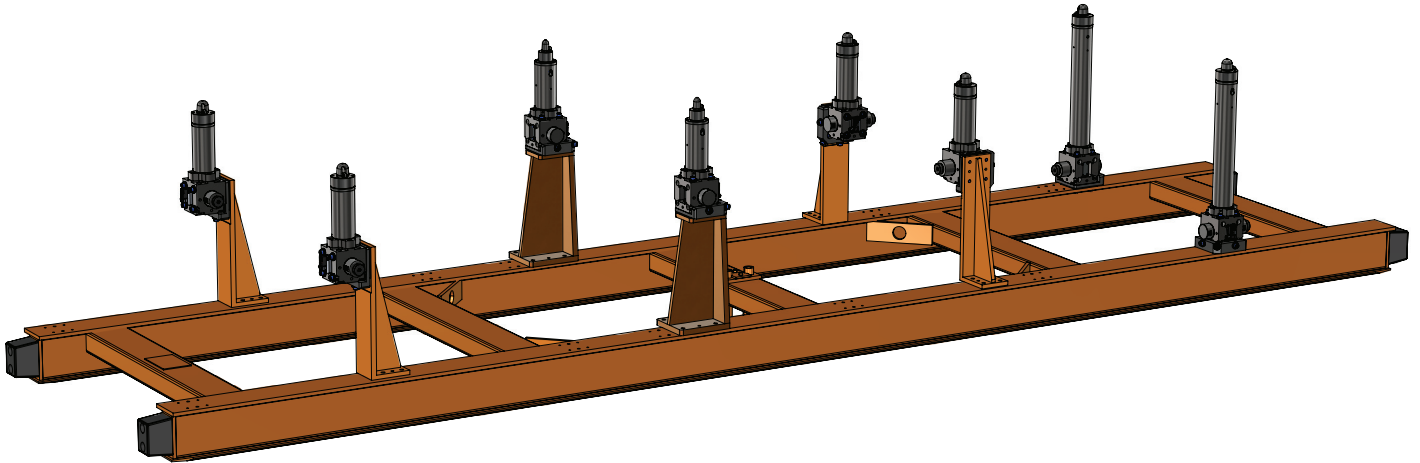

The built in pin riser allows weld gun arms to easily clear the clamp mechanism & mounting brackets, and to reach the area around the pin and into deeper cross sections reducing the need for complex brackets and risers.

The proven Locking Pin Clamp maintains clamping force with air removed for the accurate and inexpensive transfer of parts in moving tooling and fixtures.

The 3mm clamp locking range accommodates multiple part thicknesses and/or the tolerance in material thickness.

WHAT IS THE ADVANTAGE OF A PIN CLAMP?

Pin Clamps utilize precisely located datum holes which are controlled for accurate and easy assembly.

Pin Clamps combine a locator pin with a power clamp to reduce the number of components required to locate and hold parts being assembled.

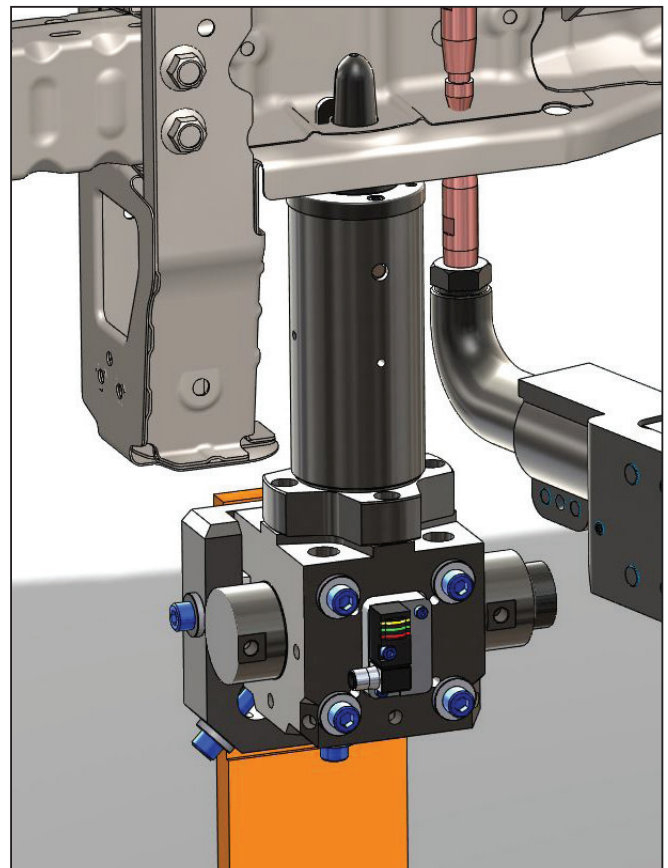

OTHER ADVANTAGES OF THE XPC LOCKING PIN CLAMP

SAVE MONEY ON CLAMP FIXTURES!

Reduces cost and improves clearance and rigidity with direct to pallet or base mounting.

Multiple extension lengths are available for access into difficult to reach areas.

Mounts to standard risers or direct to base.

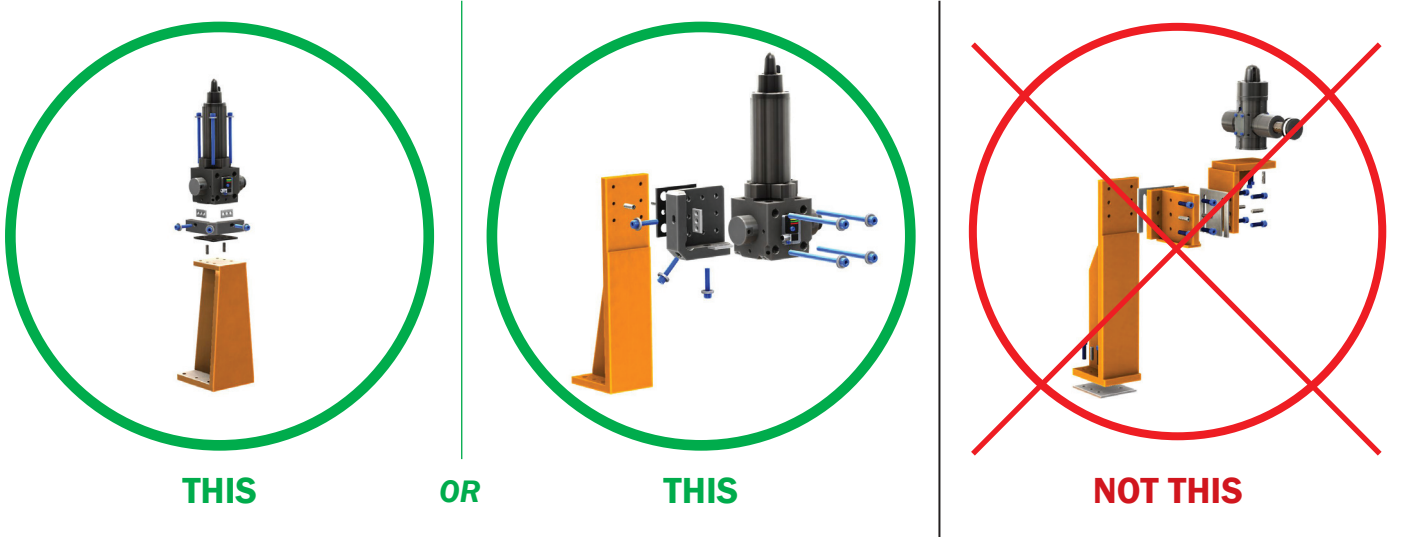

OFFSET CLAMP FINGER DESIGN ALLOWS LOCATING ACROSS SLOTS OR IN SQUARE HOLES!

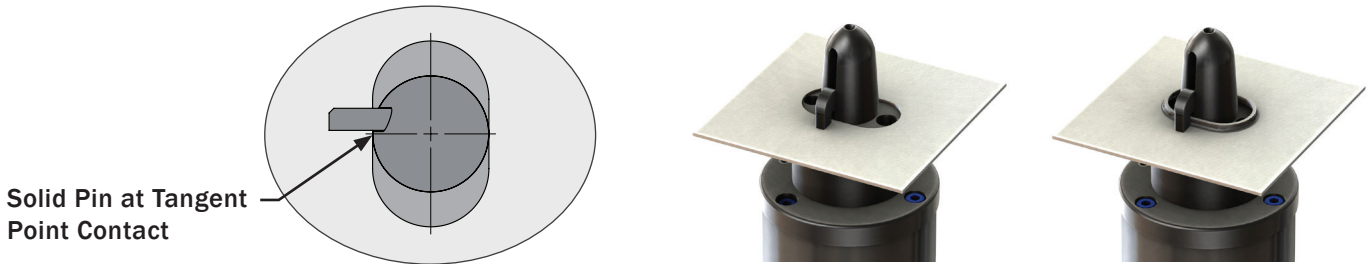

NEED TO ROTATE THE FINGER AWAY FROM FLANGES, OBSTRUCTIONS, OR WELDING OPERATIONS?

Finger can be rotated to 90° positions to avoid flanges, obstructions or weld contamination.

Simply remove four screws and rotate the upper assembly in any one of four directions.

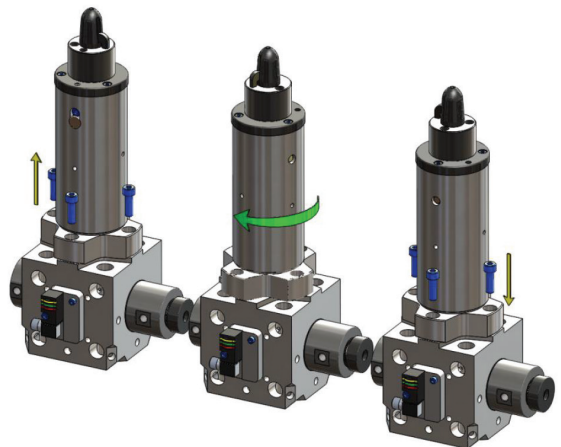

MORE ADVANTAGES

- Improved resistance to weld contamination.
- Symmetric design allows accessibility to fasteners, proximity switches or camera sensing from any side.
- XPCs use a small volume of air to generate a high clamping force.
- The XPC Pin Clamp maintains its locked clamp position when air pressure is removed.
- When the air is removed, XPC's can be manually unlocked by simply pulling on the rod end of the cylinder to release the work piece, or to retract the unit when fitting the work piece to a new fixture.

XPC PIN CLAMP COMPONENTS

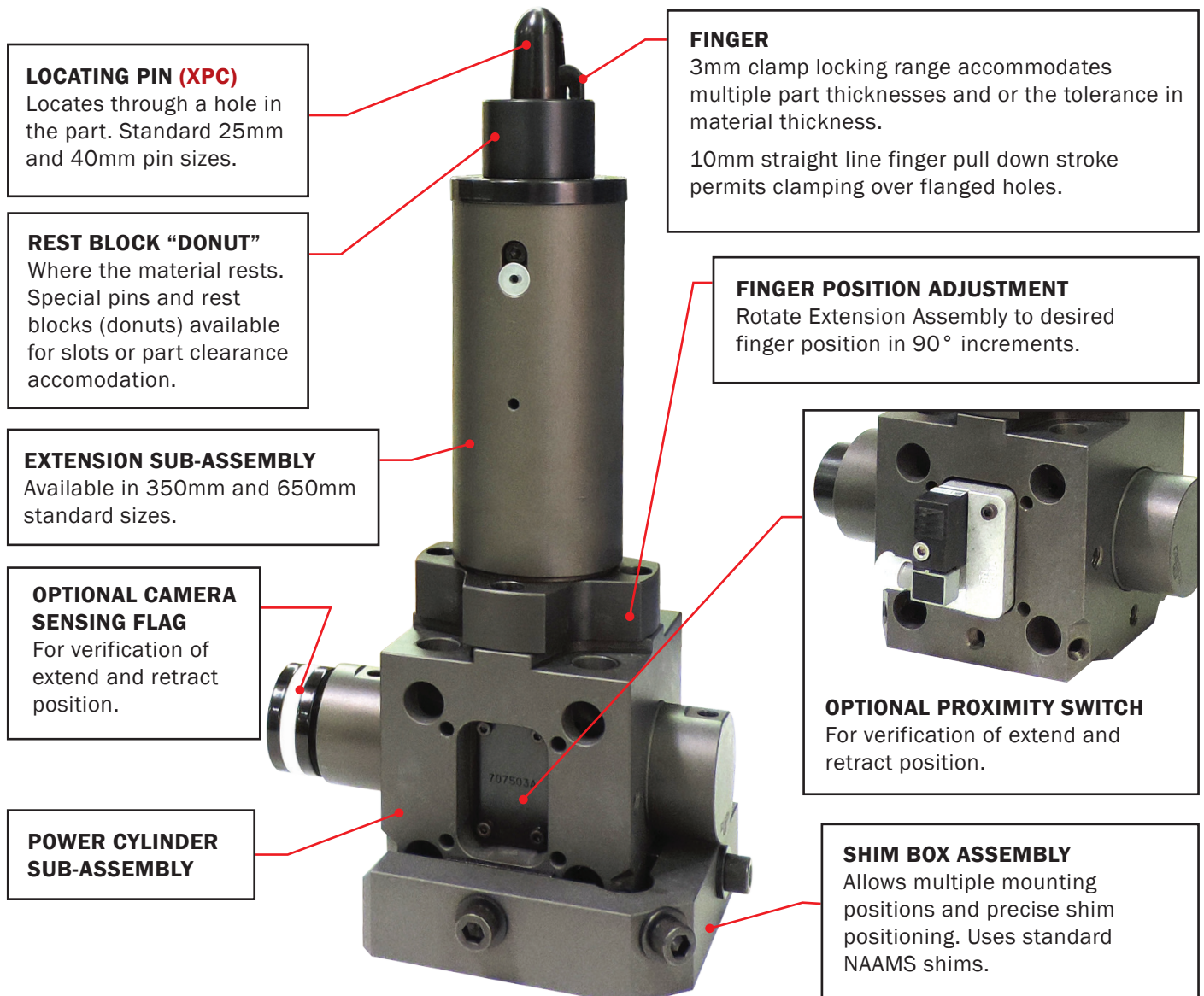

XPC SPECIFICATIONS

Standard Hole/Slot Size	24.8, 25, 39.8, 40mm		
Clamping Force	890 - 1334N @ 5.5BAR (200-300lbf @ 80PSI)		
Finger Travel	15mm Total. Consists of: <ul style="list-style-type: none"> • 5mm rotational • 10mm straight line pull down stroke • 3.0mm Locking Range (from clamping surface) 		
Bore Diameter	38.1mm - 1140mm ²		
Cylinder Stroke	38.5mm		
Clamp Weight	Clamp Height	Pin Diameter	Weight
	350	24.8 & 25	7.3kg [16.1lbs]
		39.8 & 40	8.2kg [18.1lbs]
	650	24.8 & 25	10.8kg [23.7lbs]
39.8 & 40		11.6kg [25.6lbs]	

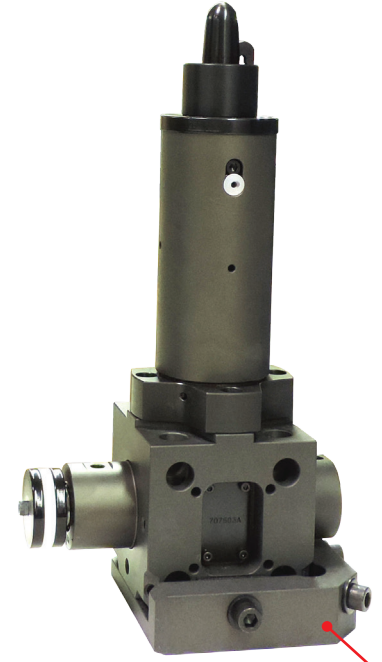

Shim Box Assembly
BTM Number
PD281300M
NOTE: Order Shim Box Separately.
See p. 14-15 for more information

HOW TO ORDER

Call +1-810-364-4567, or email sales@btmcorp.com to request a quote!

CLAMP SELECTION		PIN SELECTION					SENSING	Special Assembly Number
XPC	G	25.0	F	B	350	1	P1	XXXXXXX
CLAMP SERIES	PORT OPTION	Pin Diameter (h6 Tolerance)	Hole Type	Pin Coating	Clamp Height	Finger Position	Sensing Option	We Do Specials!
	N = 1/8 NPT G = G1/8	24.8 25.0 39.8 40.0 See p.7	F = Flanged S = Standard 	B = Black Oxide	350 650 See p.8	1 2 3 4 See p.7	Pepperl & Fuchs DC Proximity Switch: P1 = Switch Position 1 P2 = Switch Position 2 C = Camera Sensing N = No Switch See p.7	BTM Pin Clamps can be ordered with custom designed (non-standard) pins, donuts, and/or fingers. In such cases, a SPECIAL ASSEMBLY number will be issued by BTM's Product Engineering Department. This number must be referenced when ordering a non-standard pin clamp. Example of a special "donut"

XPC ORDERING OPTIONS

PIN DIAMETERS

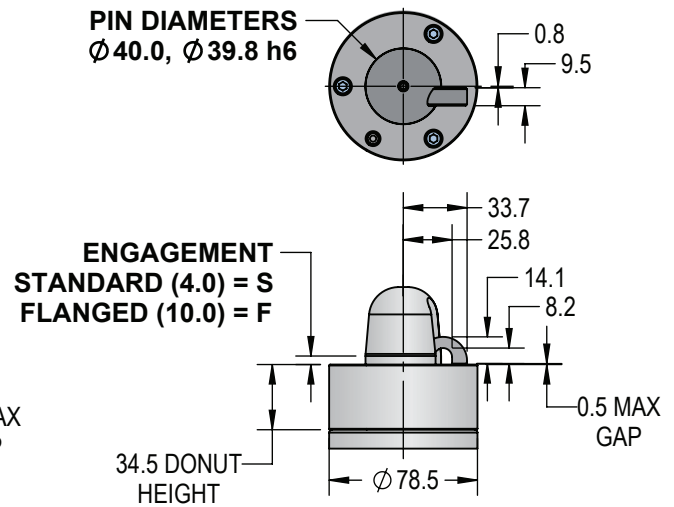
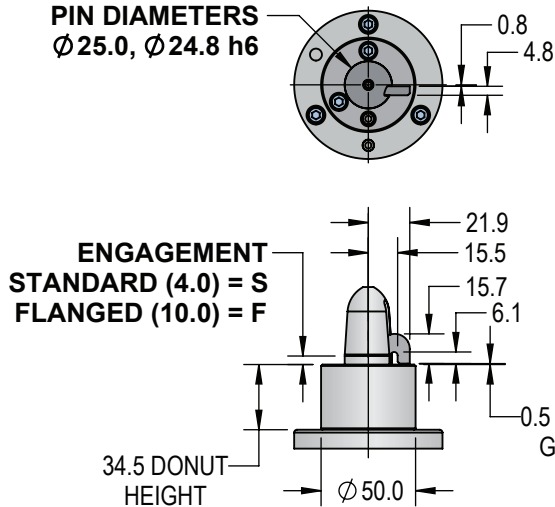

FINGER POSITION

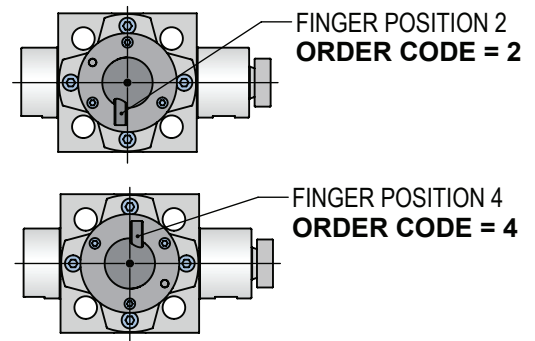
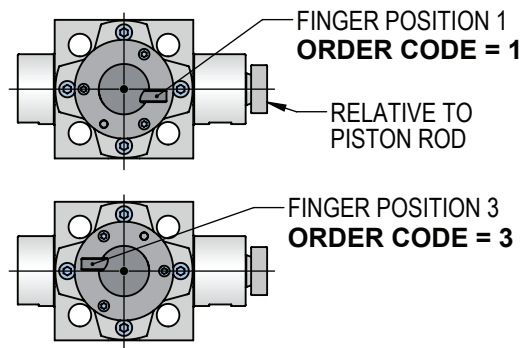

SENSING OPTIONS

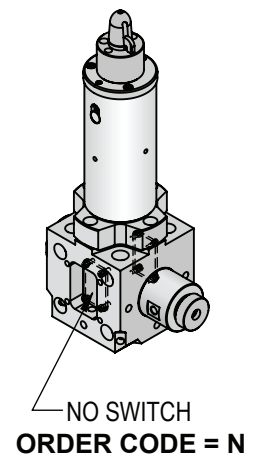
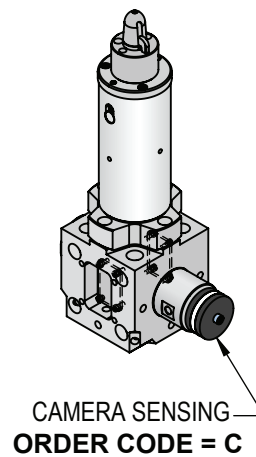
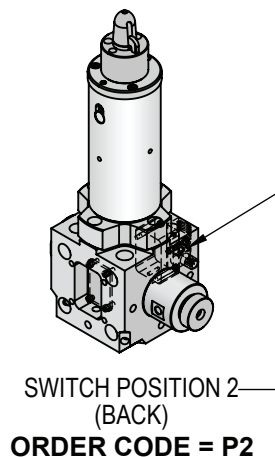
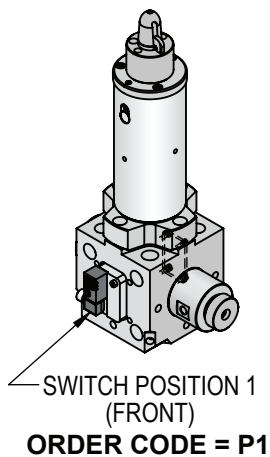

XPC DIMENSIONS

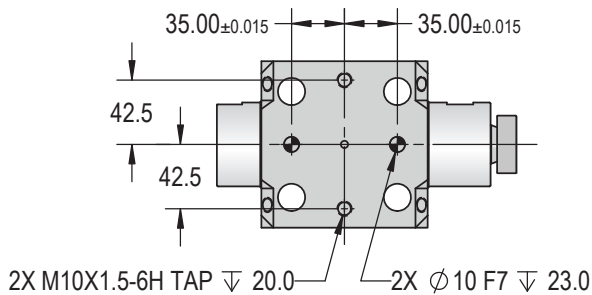
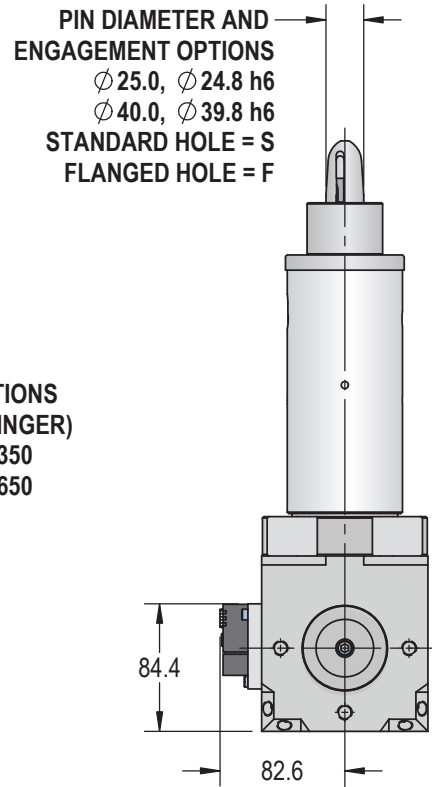
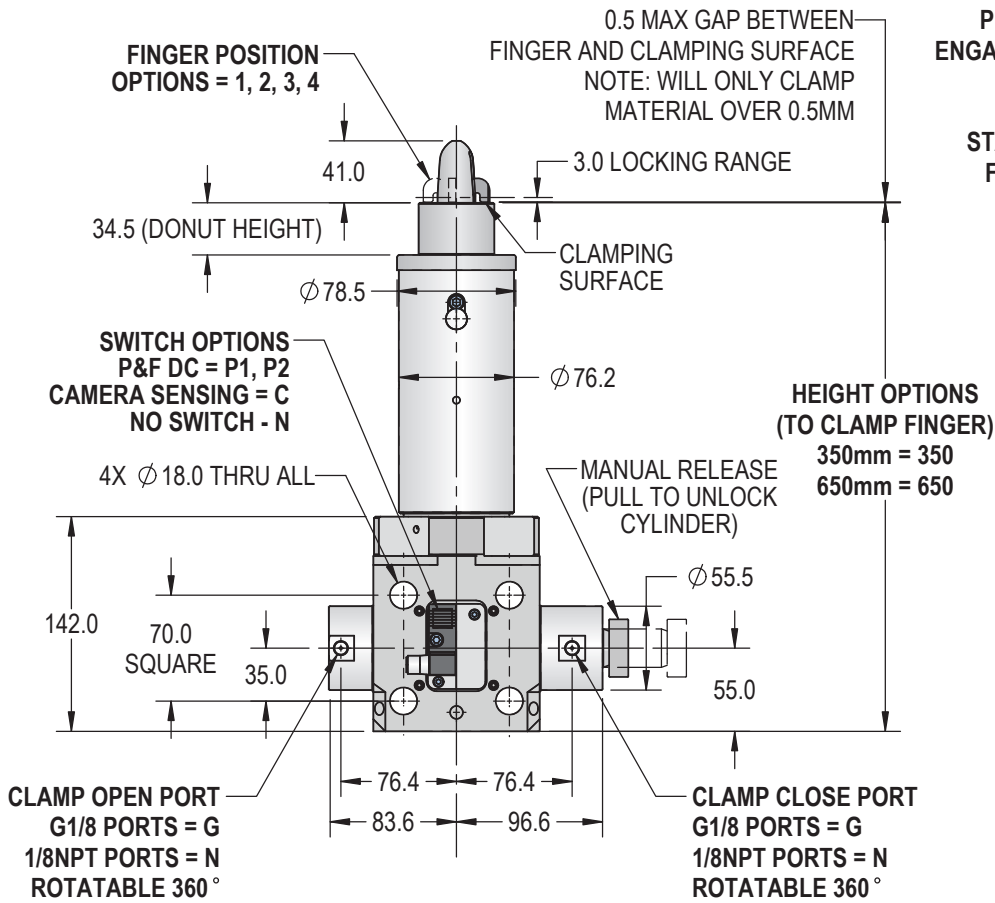
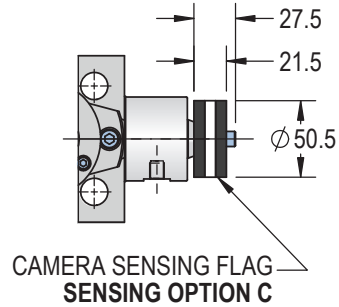
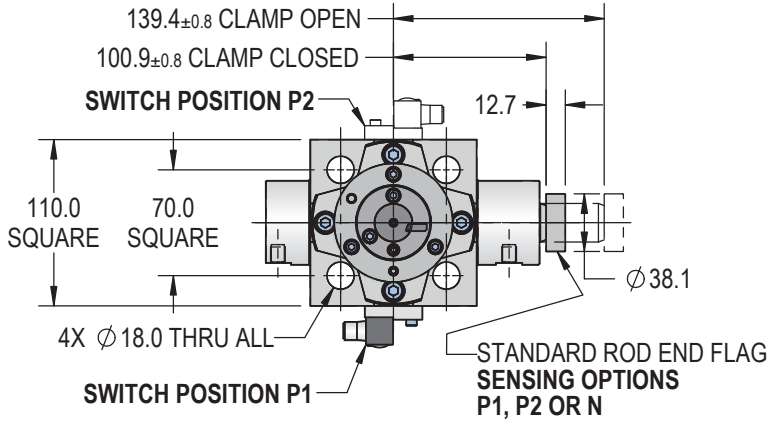

XPC SPECIAL ORDERS

**NEED A SPECIAL PIN, DONUT, OR EVEN CLAMP FINGER?
WE SPECIALIZE IN SPECIALS!**

Custom Pin Locators, Clamp Fingers, Donuts & Clamp Locking on material > 3mm are available.

Contact our sales engineering department to find out how to customize your clamp order for your unique project's needs.

CONTACT BTM TODAY!

Phone: +1-810-364-4567

Email: sales@btmcorp.com

Or visit us on the web at

www.BTMcomp.com

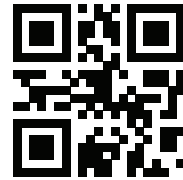

Scan this QR Code to call BTM!

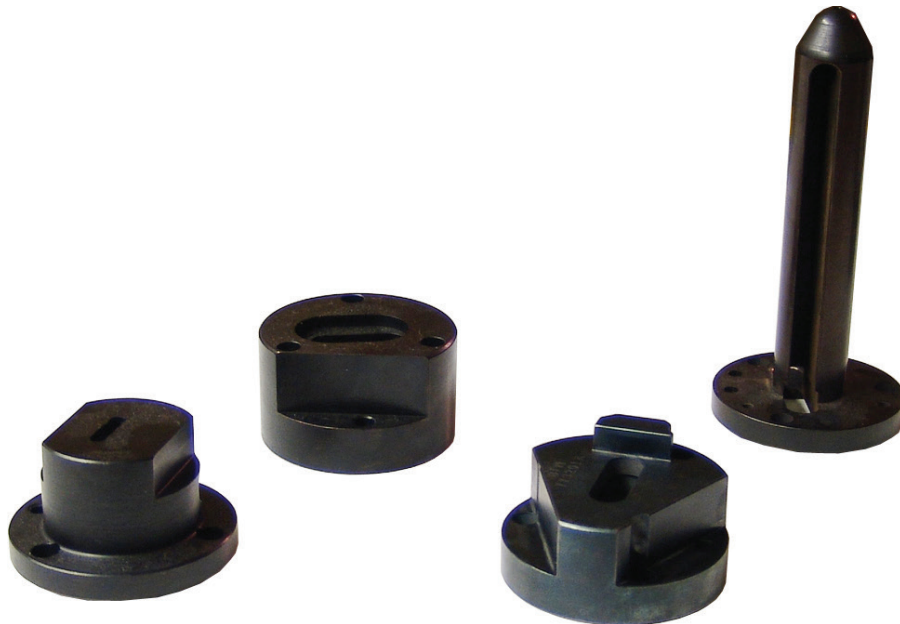

Examples of customized donuts, and a custom length pin.

XFC SPECIFICATIONS

Standard Hole/Slot Size	25 - 40mm	
Clamping Force	890 - 1334N @ 5.5BAR (200-300lbf @ 80PSI)	
Finger Travel	15mm Total. Consists of: <ul style="list-style-type: none"> • 5mm rotational • 10mm straight line pull down stroke • 2.5mm Locking Range (from clamping surface) 	
Bore Diameter	38.1mm - 1140mm ²	
Cylinder Stroke	38.5mm	
Clamp Weight	Clamp Height	Weight
	350	7.48kg [16.5lbs]
	650	10.89kg [23.6lbs]



Shim Box Assembly
BTM Number
PD281300M
NOTE: Order Shim Box Separately.
See p. 14-15 for more information

HOW TO ORDER

Call +1-810-364-4567, or email sales@btmcorp.com to request a quote!

CLAMP SELECTION		PIN SELECTION			SENSING	Special Assembly Number
XFC	G	25.0	350	1	P1	XXXXXXX
CLAMP SERIES	PORT OPTION	Finger Size	Clamp Height	Finger Position	Sensing Option	We Do Specials!
	G = G1/8	25.0	350	1	Pepperl & Fuchs DC Proximity Switch:	BTM Pin Clamps can be ordered with custom designed (non-standard) pins, donuts, and/or fingers. In such cases, a SPECIAL ASSEMBLY number will be issued by BTM's Product Engineering Department. This number must be referenced when ordering a non-standard pin clamp.
		40.0	650	2	P1 = Switch Position 1	
		See p.11	See p.12	3	P2 = Switch Position 2	
				4	C = Camera Sensing	
				See p.11	N = No Switch	
					See p.11	

Example of a special "donut"

XFC ORDERING OPTIONS

FINGER SIZES

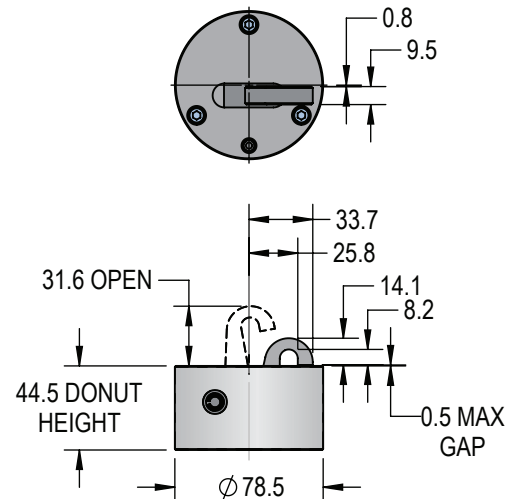
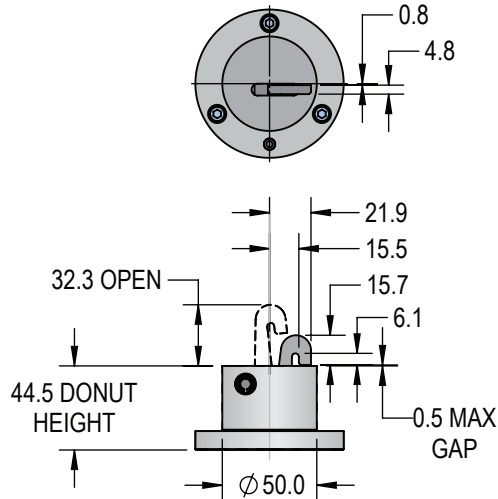

FINGER POSITION

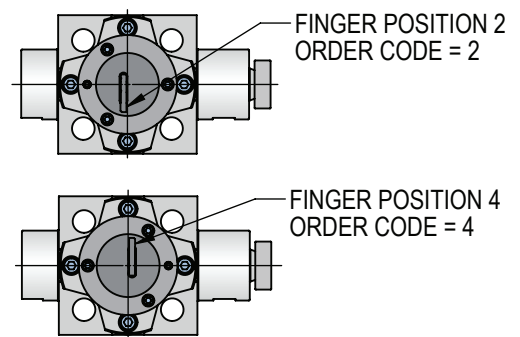
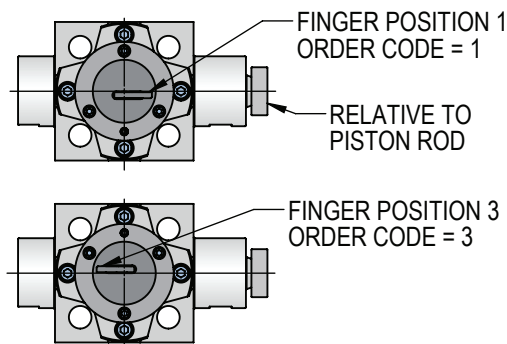

SENSING OPTIONS

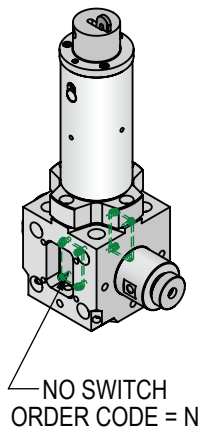
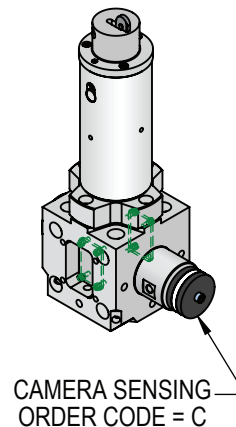
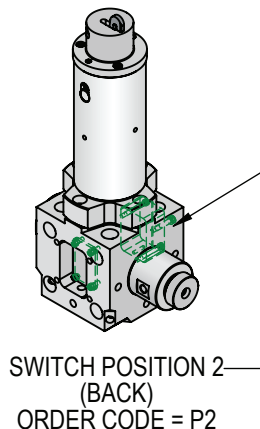
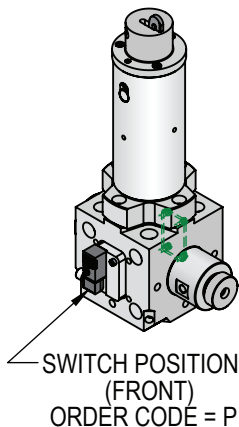

XFC DIMENSIONS

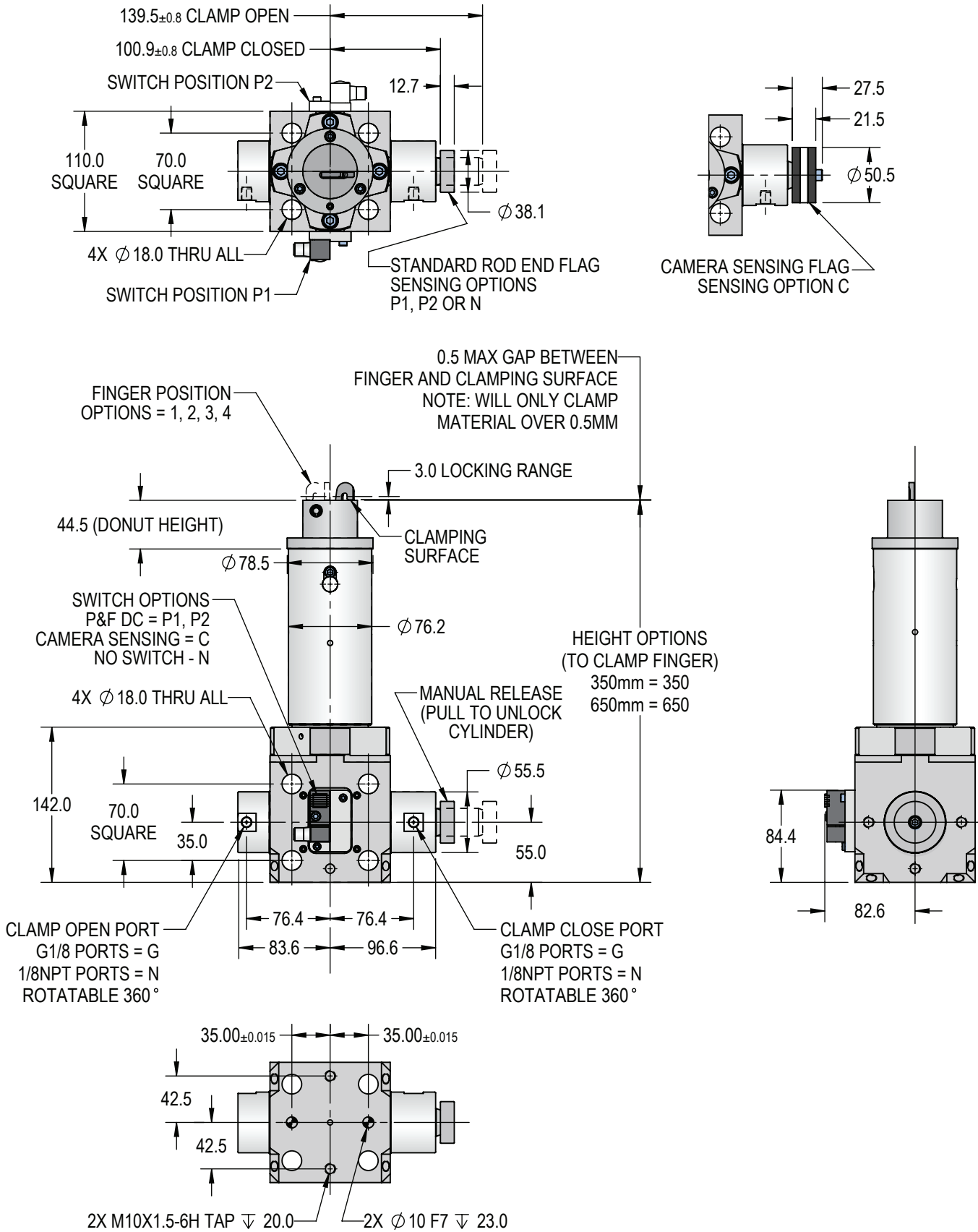

XFC SPECIAL ORDERS

**NEED A SPECIAL DONUT, OR CLAMP FINGER?
WE SPECIALIZE IN SPECIALS!**

Custom Clamp Fingers, Donuts & Clamp Locking on material > 3mm are available.

Contact our sales engineering department to find out how to customize your clamp order for your unique project's needs.

CONTACT BTM TODAY!

Phone: +1-810-364-4567

Email: sales@btmcorp.com

Or visit us on the web at

www.BTMcomp.com

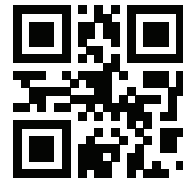

Scan this QR Code to call BTM!

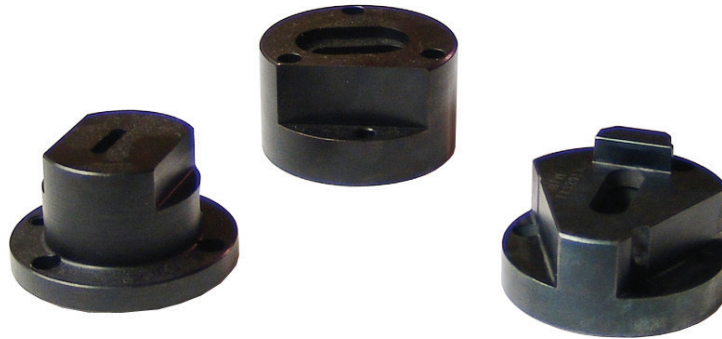

Examples of customized donuts

SHIM BOX ASSEMBLY

EQUIPPED WITH 5MM FITTING SPACERS

BTM Number
PD281300M
(Use this number when ordering.)

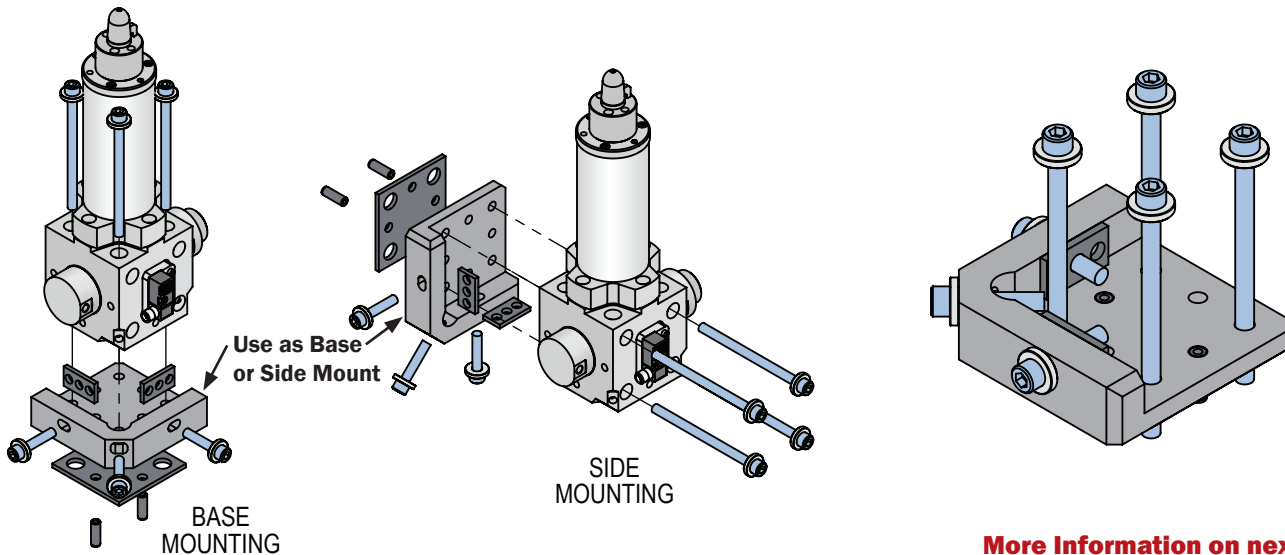
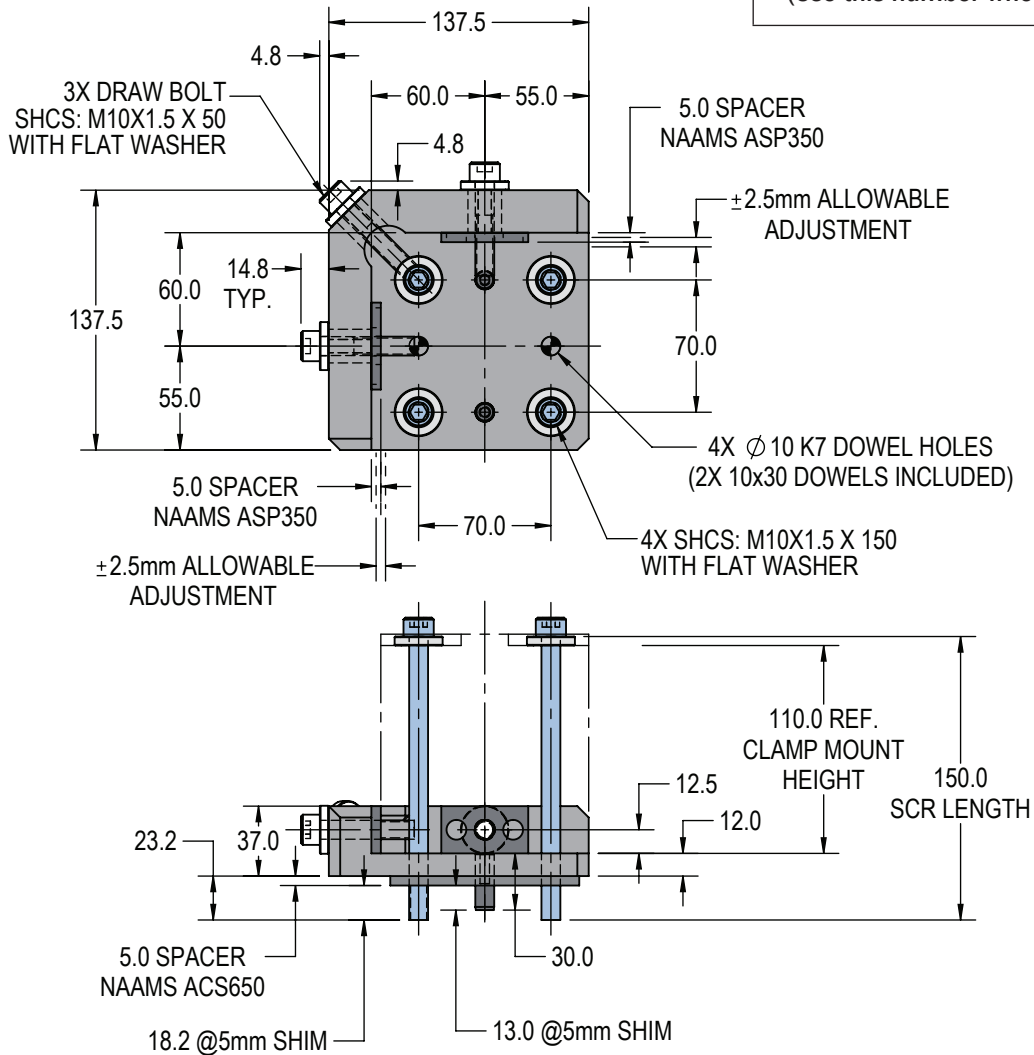

More Information on next page...

SHIM BOX ASSEMBLY (CONTINUED)

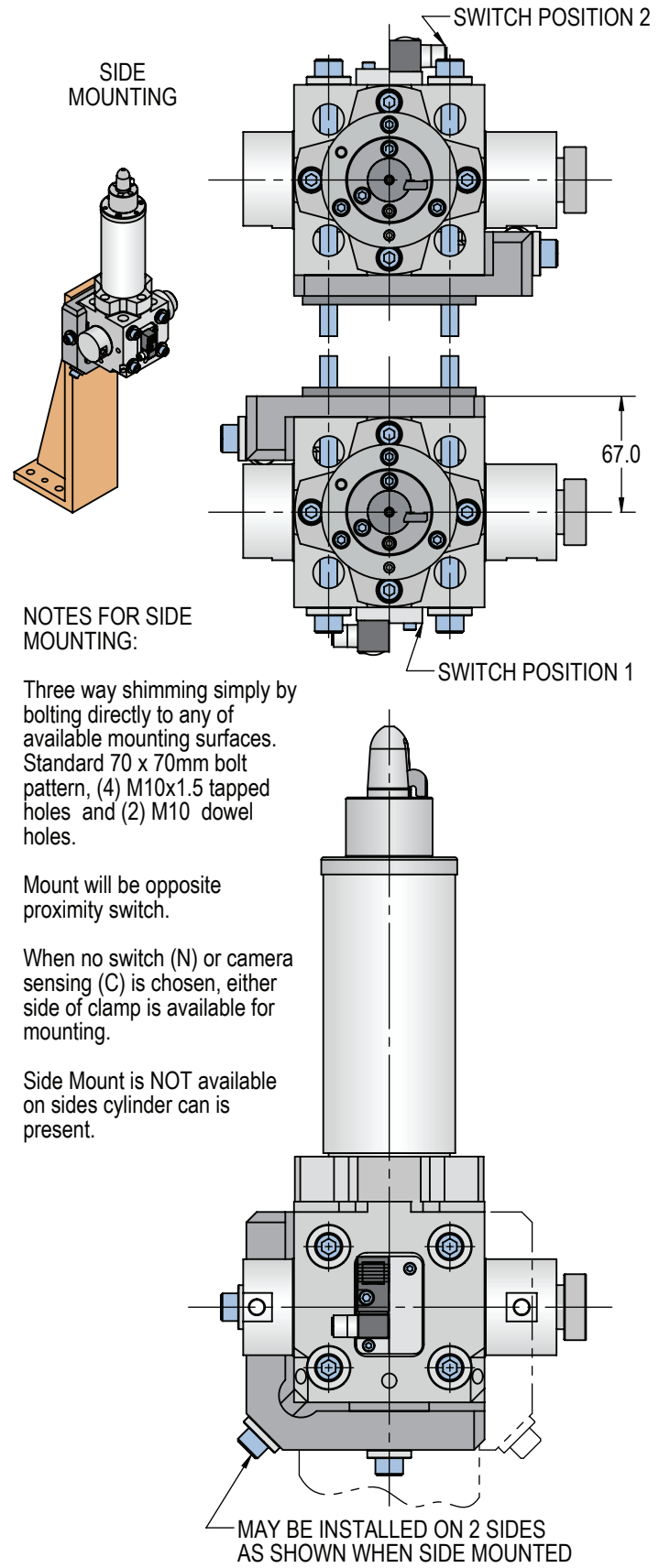
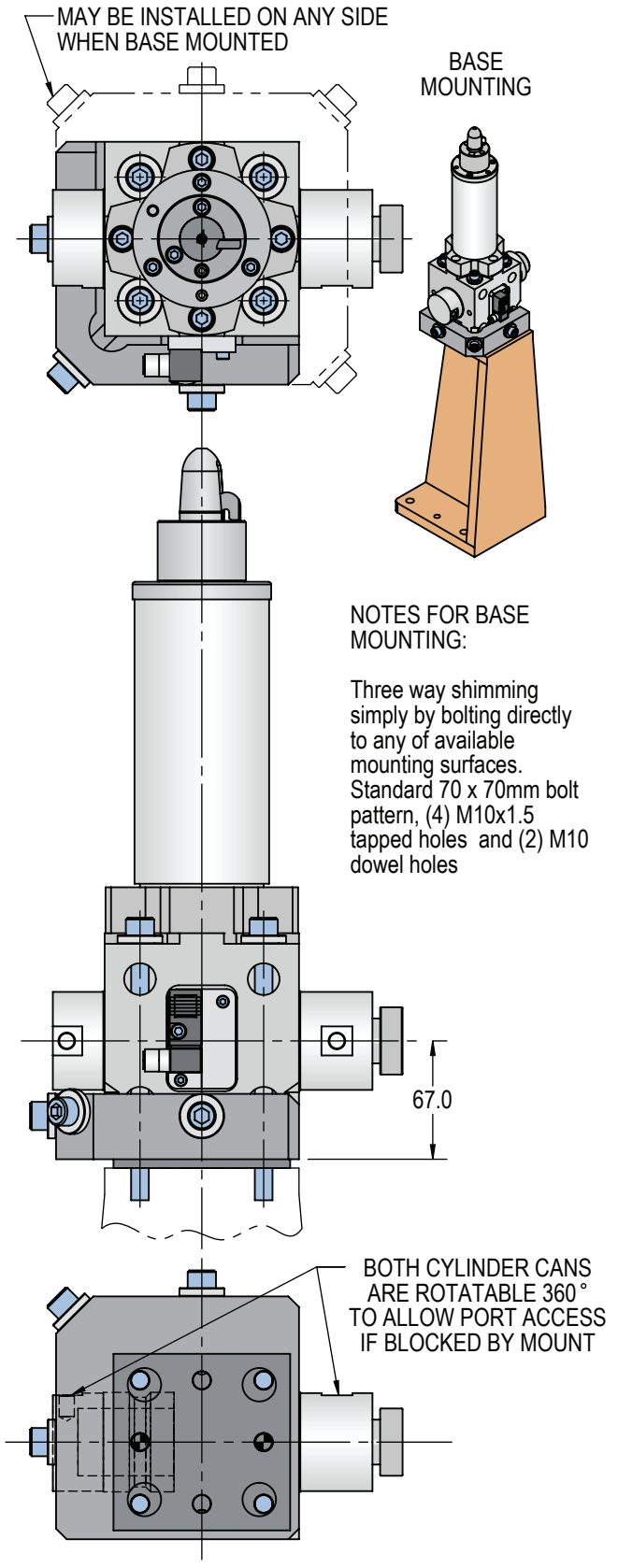



WARRANTY INFORMATION

BTM Company, LLC. warrants its Pin and Hook Clamps against defects in material and workmanship for one (1) million cycles or a period of three (3) years after the ship date from BTM, which ever comes first.

This warranty is limited to replacing or repairing at BTM's option, F.O.B. BTM's factory, any part found by BTM to be defective in materials and/or workmanship. Any application of a BTM product outside the intended use of the product shall not be warranted by BTM Company, LLC. Furthermore, BTM will not be liable for any expenses incurred for repairs or replacement made outside BTM's facilities without written consent (or damages arising out of such replacements or repairs). Under no circumstances will BTM be held responsible for any consequential damages.

The warranty is limited to the repair or replacement of the defective part(s) and does not include installation.

This warranty is the only warranty extended by the seller in connection with any sale made hereunder and is in lieu of all other warranties, express, implied or statutory including warranties of merchantability and fitness for purpose.

OTHER PIN LOCATOR CLAMPS FROM BTM



Model	Hole/Slot Range	Locking?	Manual Option Available?
PLC-25	6-12mm	No	No
PLC-45	12.5-18mm	No	No
PLC-63	18-40mm	No	Yes
RLPC-45	12.5-18mm	Yes	Yes
RLPC-63	18-40mm	Yes	Yes
LPLC-38	18-40mm	Yes	Yes



For more information, or to view our other products, please visit:

www.BTMCOMP.COM