



Rechargeable battery clinch and pierce unit ULBG 452

BTM

[Europe]
Blechverbindungstechnik
GmbH



**Exchangeable
tool holder!**



Battery &
main operation



Single-hand
control



Features:

- **Clinch operation:**
Up to 4 mm in mild steel, up to 4 mm in mild aluminium
- **Pierce operation:**
Max. sheet metal thickness depends on size of punching hole
- **Ergonomic** design
- Stroke limitation by mechanical device
- Handling weight incl. rechargeable battery only **3.7 kg¹**
- Tool holder turnable to **360°**
- Various **tool holders** available as C-frame and X-frame
- Quick press stroke with automatic back stroke via single handed control
- Powerful **Li-Ion** rechargeable battery for optimal power
- USB connection for process control
- Main supply also by cable (220 V/110 V)

¹C- frame (Steel) with 38 mm throat depth

BTM [Europe] Blechverbindungstechnik GmbH
Handwerkerstraße 6 · D-59597 Erwitte
Tel.: +49 (0) 29 43/97 90-0 · Fax +49 (0) 29 43/97 90-90
www.btm-europe.de · info@btm-europe.de

Location South: BTM [Europe] Blechverbindungstechnik GmbH
Am Fuchsgraben 13 · D-77880 Sasbach/Ortenau
Tel.: +49 (0) 78 41/681 36 0 · Fax +49 (0) 78 41/681 36 25
www.btm-europe.de · info-sued@btm-europe.de

BTM



Rechargeable battery clinch and pierce unit ULBG 452



[Europe]
Blechverbindungstechnik
GmbH

The new **BTM clinch and pierce unit ULBG 452** is characterized by its compact, ergonomic construction principle and its high joining force. In addition to efficient Li-Ion rechargeable batteries the unit is also optionally available with a power supply for all common voltage systems.

Due to its low handling weight, the slim construction and the fast piston speed operating in narrow areas is well possible.

The stroke is activated by one push button, when reaching the front position retract stroke will be initiated automatically. The procedure can be interrupted at any time.

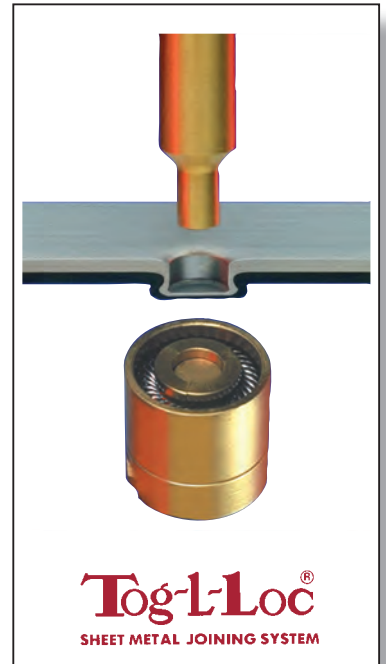
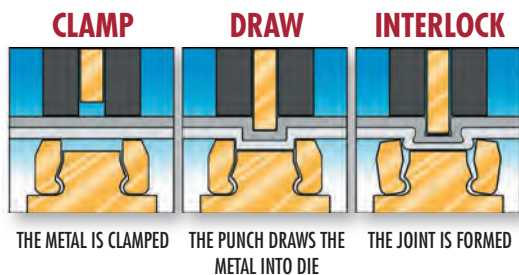

Technical details ULBG 452

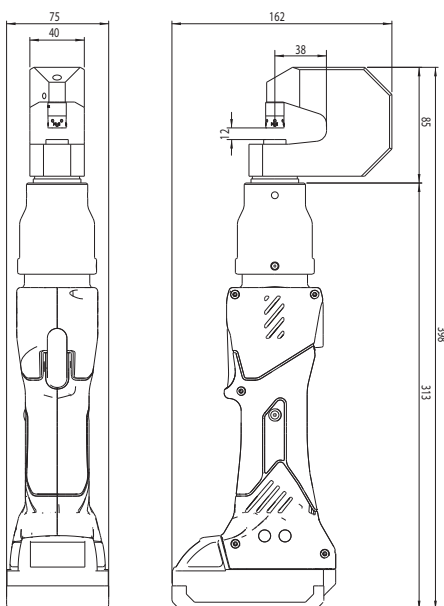

Weight with battery:	2,2 kg unit only
Total weight:	3,7 kg with 38 mm C-frame
Max. clinch force:	20-45 kN adjustable
Power stroke:	12-18 mm adjustable
Cycle time:	depends on length of stroke
Clinch tooling ¹ :	punch and die reversibly exchangeable
Rechargeable battery:	18V/1,5 Ah Li-Ion
Battery capacity:	approx. 200 strokes - depends on length of stroke -
Charging time:	approx. 30 min

¹depends on style of tooling head

Scope of supply:
Power unit, tooling head with clinch or punch tool, rechargeable battery, charger

BTM [Europe] Blechverbindungstechnik GmbH
Handwerkerstraße 6 · D-59597 Erwitte
Tel.: +49 (0) 29 43/97 90-0 · Fax +49 (0) 29 43/97 90-90
www.btm-europe.de · info@btm-europe.de

Location South: BTM [Europe] Blechverbindungstechnik GmbH
Am Fuchsgraben 13 · D-77880 Sasbach/Ortenau
Tel.: +49 (0) 78 41/681 36 0 · Fax +49 (0) 78 41/681 36 25
www.btm-europe.de · info-sued@btm-europe.de

