

HAND HELD CLINCHING UNITS

Manually positioned units for clinching sheet metal parts.



> PNEUMATIC



> AIR/OIL



> HYDRAULIC



> BATTERY



Part of our Clinching Production Equipment line of Products

www.btmcomp.com/clinching-equipment.html



BTM
EUROPE

www.btm-europe.de

BTM CLINCHING

BTM Tog-L-Loc[®] and related clinching tools economically join sheet metal without the expense of welding or purchased fasteners by simply joining the part's own material! Assembly cost is significantly reduced by drawing and forming the part material into an interlock. Join galvanized, pre-painted, or even dissimilar metal combinations using an environmentally friendly process that does not produce sparks, fumes or harmful heat!

HOW A TYPICAL BTM CLINCH JOINT IS MADE:

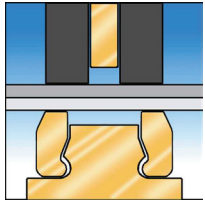
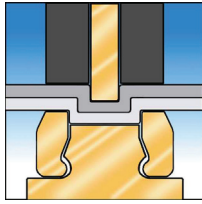
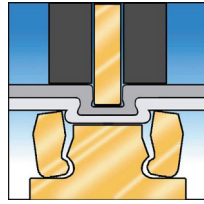
Step 1: Clamp

Step 2: Draw

Step 3: Lock
Step 1: Clamps

The stripper clamps the materials to be joined.

Step 2: Draws

The punch draws the material into the die.

Step 3: Locks

As the material flows into the die, the sides of the die expand, allowing the material to flow into an interlock.

TO LEARN MORE:

www.btmcomp.com/clinching-solutions.html

	ROUND JOINTS		Geo-Clinch [®] JOINTS	
				
	Tog-L-Loc[®]	V-Loc[™]	Oval-Loc[™]	Lance-N-Loc[™]
Ideal for joining:	Mild Steel	Aluminum	Mild Steel	Harder Metals
Leak-Proof	Yes	Yes	Yes	No
Single Joint Rotation Resistance?	No	No	Yes	Yes

Tog-L-Loc[®] and V-Loc[™] clinch joints are the most widely used. These round clinch joints have very good strength across a broad spectrum of material combinations, are aesthetically pleasing and at low cost. V-Loc[™] performs especially well when joining combinations of aluminum. BTM's round clinch joints are an economical solution to fastening sheet metal parts. However, round joints, while most popular, have the ability to rotate when used singularly, so BTM also offers Geo-Clinch[®] joints.

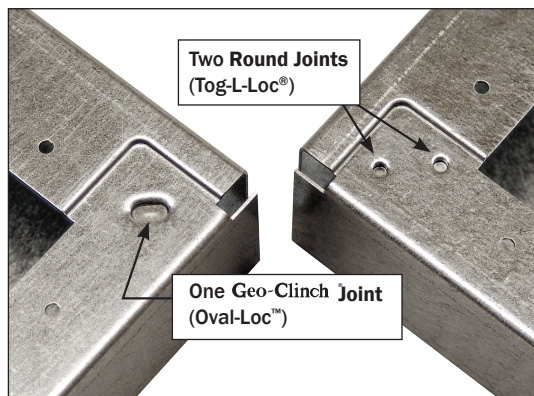

Geo-Clinch[®] JOINTS

BTM's Geo-Clinch[®] joints resist rotation, and also have the added benefit of increasing the rigidity of a sheet metal assembly.

Geo-Clinch[®] joints set the combined geometry of two separate parts in an assembly as required by GD&T. This makes Geo-Clinch[®] joints ideal for use in Geo-Set applications.

! BTM reserves the right to make changes to its literature without any prior notice. Go to www.btm-europe.de for latest version.

BTM[®] HAND HELD UNITS

BTM hand held clinching units provide an inexpensive way to begin reducing the cost of assembling your product and can serve as an affordable stepping stone to higher production from a more automated machine. Our broad range of standard and adaptable hand held units are designed to fit a wide range of part designs and production requirements or we can easily modify an existing unit to meet your unique part design.

Contact our Sales department at [info@btm-europe.de!](mailto:info@btm-europe.de)

UNIT SELECTION

PNEUMATIC UNITS

UniClinch Unit		UniCroc Unit		
				
See PAGE 6-7 For More Information		See PAGE 8-9 For More Information		
Clinch Joint Type	Round	Clinch Joint Type	Round	LanceN^{LoC}
Tool Sizes	3.0, 3.8, 4.6*	Tool Sizes	3.8, 4.6*	3.0
Max. Combined Material Thickness	2mm [.08"]	Max. Combined Material Thickness	2mm [.08"]	
Opening	6mm [.25"]	Opening	6mm [.25"]	
Throat Depth	Varies per Anvil	Throat Depth	30mm [1.18"]	
Trigger Type	Single	Trigger Type	Single	
Operating Pressure	6 BAR [87 PSI]	Operating Pressure	6 BAR [87 PSI]	
Cycle Time	1.5 second	Cycle Time	1.5 second	
Unit Weight	Roughly 4kg [8.9 lb]	Unit Weight	5.7 kg [12.5 lbs]	

* 4.6 Tooling- Some Limitations Apply. [Contact BTM.](mailto:info@btm-europe.de)

AIR/OIL BOOSTER POWERED UNITS

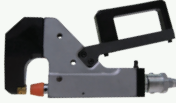
Lit-L-Loc Units		Duroloc7 Unit	
			
See PAGE 10-11 For More Information		See PAGE 12-13 For More Information	
Clinch Joint Type	ToggleLoc or LanceN^{LoC}	Clinch Joint Type	Round
Tool Sizes	3.0, 4.6	Tool Sizes	3.8, 4.6
Max. Combined Material Thickness	2mm [.08"]	Max. Combined Material Thickness	2mm [.08"]
Opening	6mm [.25"]	Opening	6mm [.25"]
Throat Depth Range	6.2mm [.24"] - 76.2mm [3.00"]	Throat Depth	38mm [1.50"]
Trigger Type	Single	Trigger Type	Single
Max. Operating Pressure	345 BAR [5000 PSI]	Max. Operating Pressure	345 BAR [5000 PSI]
Cycle Time	1 second	Cycle Time	1 second
Unit Weight	Varies with Unit	Unit Weight	5.6 kg [12.4 lbs]

More Air/Oil Booster Powered Units on Next Page..

AIR/OIL BOOSTER POWERED UNITS
Bayonet Units
Standard Bayonet

 See
**PAGE
 14-15**

For More Information

Clinch Joint Type	Round
Tool Sizes	3.0, 3.8, 4.6
Max. Combined Material Thickness	3mm [.12"]
Opening	6mm [.25"] / 47.5mm [1.87"]
Throat Depth	50mm [2.00"]
Trigger Type	Single
Max. Operating Pressure	345 BAR [5000 PSI]
Cycle Time	1.5 sec.
Unit Weight	6 kg [13.2 lbs]

Crocodile Unit

 See
**PAGE
 18-19**

For More Information

Clinch Joint Type	Round	Geo-Clinch®
Tool Sizes	3.8, 4.6	3.0, 3.8
Max. Combined Material Thickness	3.5mm [.14"]	
Part Load Opening	41mm [1.61"]	
Power Stroke Opening	6mm [.24"]	
Throat Depth	50mm [2.00"]	
Trigger Type	Single	
Max. Operating Pressure	345 BAR [5000 PSI]	
Cycle Time	1.5 sec.	
Unit Weight	8.8kg [19.5 lbs]	

Adaptable Bayonet

 See
**PAGE
 16-17**

For More Information

Same Specifications as Standard Bayonet Except:

Clinch Joint Type	Round or Lance-N-LoC™
Throat Depth	Customer Specified
Unit Weight	Varies

AIR/OIL BOOSTERS

 See
**PAGE
 20-21**

For More Information

15cc Booster
49cc Booster

Booster Ratio	61:1	64:1
Weight (without hose)	8.2kg [18 lbs]	17.8kg [39 lbs]
Max. Output	337 BAR [4880 PSI] @ 5.5 BAR [80 PSI]	353 BAR [5120 PSI] @ 5.5 BAR [80 PSI]

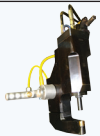
HYDRAULIC POWERED UNITS
7006 Unit

 See
**PAGE
 22-23**

For More Information

Clinch Joint Type	Round
Tool Sizes	3.0, 3.8, 4.6
Max. Combined Material Thickness	4mm [.16"]
Opening	32mm [1.26"]
Stroke	35mm [1.38"]
Throat Depth	50mm [1.97"]
Trigger Type	Dual
Operating Pressure	175 BAR [2500 PSI]
Cycle Time	2 sec.
Unit Weight	11.3 kg [25 lbs]

Heavy Duty 7006 Unit

 See
**PAGE
 24-25**

For More Information

Clinch Joint Type	Round
Tool Sizes	5.5
Max. Combined Material Thickness	4mm [.16"]
Opening	32mm [1.26"]
Stroke	35mm [1.38"]
Throat Depth	75mm [2.95"]
Trigger Type	Dual
Operating Pressure	175 BAR [2500 PSI]
Cycle Time	2.5 sec.
Unit Weight	22 kg [49 lbs] - 24 kg [53 lbs]

More Hydraulic Pump Powered Units on Next Page..

HYDRAULIC POWERED UNITS

Fully Adaptable Unit



See
PAGE 26-27
For More Information

Clinch Joint Type	Round or Geo-Clinch
Tool Sizes	3.0, 3.8, 4.6, 5.5, 6.4
Max. Total Material Thickness	4mm [.16"]

HYDRAULIC PUMPS

See
PAGE 28-29
For More Information



Hydraulic Pump



HydroPak2

BATTERY POWERED UNITS

Compact Battery Clinch Unit



See
PAGE 30-31
For More Information

Clinch Joint Type	Round
Tool Sizes	3.0, 3.8, 4.6
Max. Combined Material Thickness	4mm [.16"]
Power Stroke	16mm [.63"]
Throat Depth	Varies per C-Frame
Trigger Type	Single
Battery Type	18V/1.5Ah Lithium-Ion
Charging Time	Approximately 30 Minutes
Cycle Time	Contact BTM
Unit Weight	Varies with C-Frame

Battery Clinch Unit



See
PAGE 32-33
For More Information

Clinch Joint Type	Round
Tool Sizes	3.0, 3.8, 4.6, 5.5
Max. Combined Material Thickness	Contact BTM
Power Stroke	10-25mm [.39-.98"] Adjustable
Throat Depth	Varies per C-Frame
Trigger Type	Single
Battery Type	14.4V/2.6Ah Lithium-Ion
Charging Time	Approximately 45 Minutes
Cycle Time	Varies with Stroke Length
Unit Weight	Varies with C-Frame

OPTIONS & ACCESSORIES

Rotation Mounts



Duroloc7

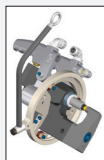

7006 Units

See
PAGE 34
For More Information

Spring Balancers



See
PAGE 35
For More Information

UNICLINCH UNITS

The UniClinch unit has an integrated air hydraulic cylinder which requires only an 87psi (6 bar) airline to operate.

The unit contains few moving parts and offers a high level of reliability.

It is also quick cycling, lightweight, well balanced and runs quietly making it an ideal solution for economically clinching your products in low to medium volume production runs.



www.btmcomp.com/uniclinch-units.html

THE UNICLINCH UNIT IS BEST WHEN:

- *Smaller clinch joints are adequate.*
- *Joining overlaps or flanges.*
- *The part does not require a large opening.*



Opening	6mm [.25"]
Trigger Type	Single
Operating Pressure	6 BAR [87 PSI]
Cycle Time	1.5 sec.
Maximum Combined Material Thickness that can be joined with this unit	2mm [.08"]

Clinch Joint Type	Round		
Tool Size(s)	3.0	3.8	4.6*

* 4.6 Tooling- Some Limitations Apply. [Contact BTM.](#)

TYPICAL APPLICATIONS FOR A UNICLINCH UNIT:

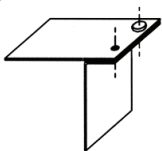
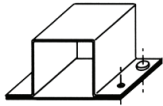
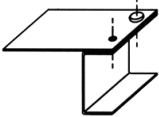
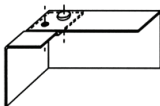
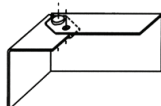
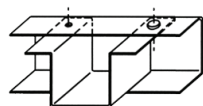
6  Outside Edge Flange	8  Hat on Sheet	9  "U" and Sheet	18  Full Corner Joggle Overlap	19  45° Corner Overlap	21  Hat inside "U"
---	---	--	--	--	--

HOW TO ORDER



It is recommended that you [contact a BTM sales engineer](#) prior to purchasing a handheld unit to determine the optimal tooling configuration for your application.

Email info@btm-europe.de to request a quote!

UniClinch Unit with C-Frame (Includes two sets of Tooling)
PD295000A
OR
PD296000A
OR
PD296000B

Spring Balancer
3-5 kg [6.6-11 lbs] 052936

UNICLINCH UNIT & C-FRAME

BTM NUMBER PD295000A

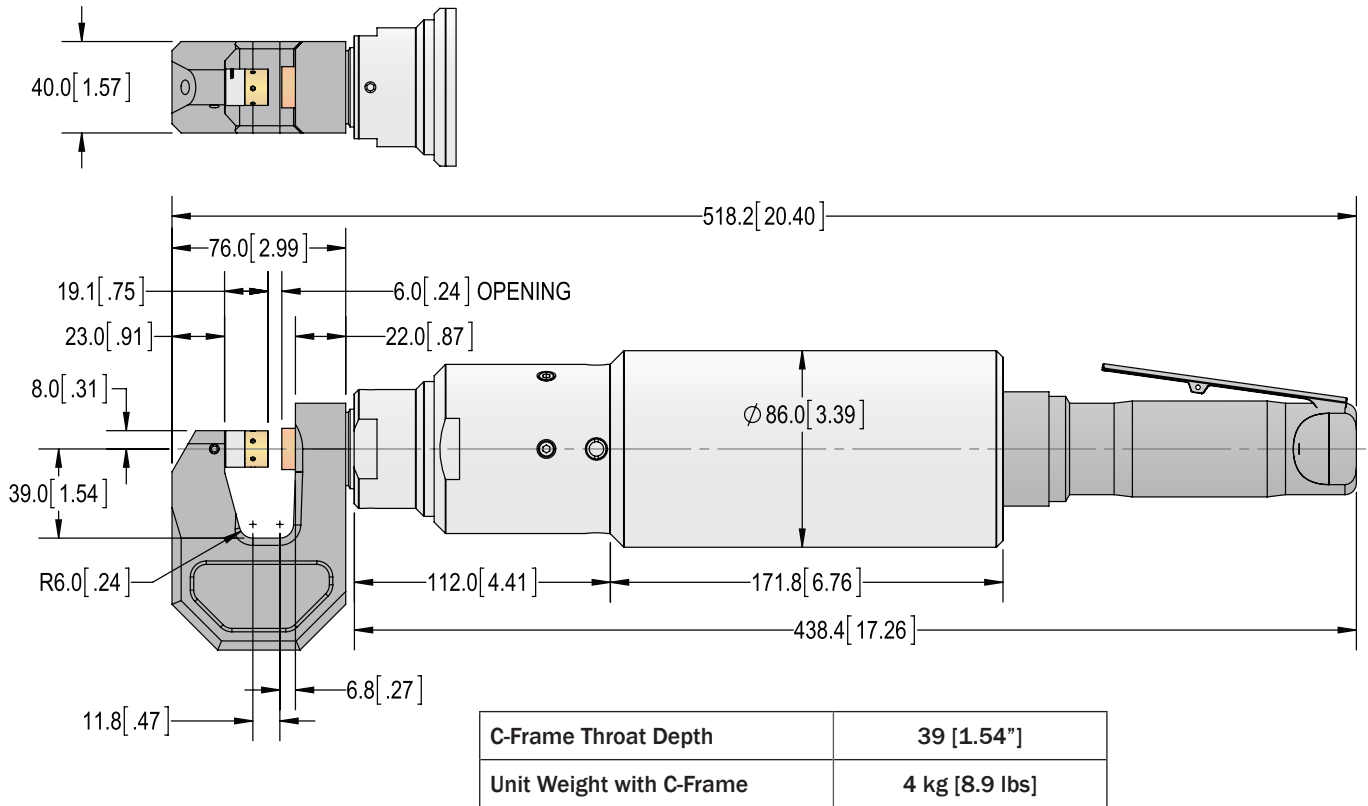

UNICLINCH UNIT & C-FRAME

BTM NUMBER PD296000A

(3.0 TOG-L-LOC ONLY)

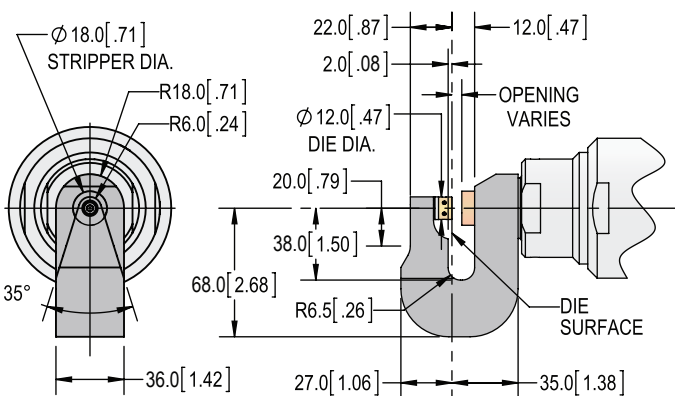

C-Frame Throat Depth	38.0 [1.50"]
Unit Weight with C-Frame	3.67 kg [8.1 lbs]

UNICLINCH UNIT & C-FRAME

BTM NUMBER PD296000B

(3.8 & 4.6 TOG-L-LOC)

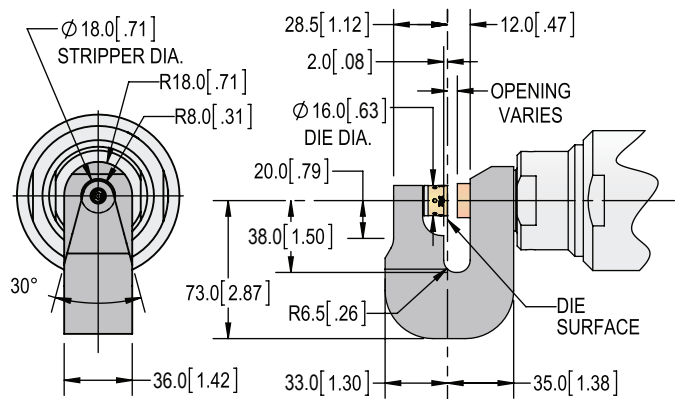

C-Frame Throat Depth	38.0 [1.50"]
Unit Weight with C-Frame	3.86 kg [8.5 lbs]

UNICROC UNIT

The UniCroc uses a lever action mechanism to provide access to standing flanges by offsetting the clinch tooling away from the integrated air-hydraulic cylinder. This also provides a more ergonomically correct manual positioning of the tool to the joint location especially when suspended vertically above the part.

This unit facilitates faster production through ease of positioning and better vision of the joint location.



www.btmcomp.com/unicroc-units.html

THE UNICROC UNIT IS BEST WHEN:

- *Joining standing flanges on close centers.*
- *Joining in a confined location.*
- *Ergonomic access and operation is required.*

Opening	6mm [.25"]
Throat Depth	30mm [1.18"]
Trigger Type	Single
Operating Pressure	6 BAR [87 PSI]
Cycle Time	1.5 sec.
Unit Weight	5.7 kg [12.5 lbs]
Maximum Combined Material Thickness that can be joined with this unit	2mm [.08"]

Clinch Joint Type*	Round	or	Lance-N-Loc™
Tool Size(s)	3.8	4.6*	3.0

* 4.6 Tooling- Some Limitations Apply. [Contact BTM.](#)

TYPICAL APPLICATIONS FOR A UNICROC UNIT:

<p>2</p> <p>Angle and Sheet</p>	<p>5</p> <p>Standing Flange</p>	<p>6</p> <p>Outside Edge Flange</p>	<p>7</p> <p>Brim to Brim</p>	<p>8</p> <p>Hat on Sheet</p>	<p>9</p> <p>"U" and Sheet</p>	<p>10</p> <p>Side To Side "U's"</p>
<p>17</p> <p>Two Piece Full Corner Overlap</p>	<p>18</p> <p>Full Corner Joggle Overlap</p>	<p>19</p> <p>45° Corner Overlap</p>	<p>21</p> <p>Hat Inside "U"</p>			

HOW TO ORDER



It is recommended that you [contact a BTM sales engineer](#) prior to purchasing a handheld unit to determine the optimal tooling configuration for your application.

Email info@btm-europe.de to request a quote!

UniCroc Unit	Spring Balancer
PD284200A Includes two sets of Tooling.	4-7 kg [10-15 lbs] 052937

UNICROC UNIT

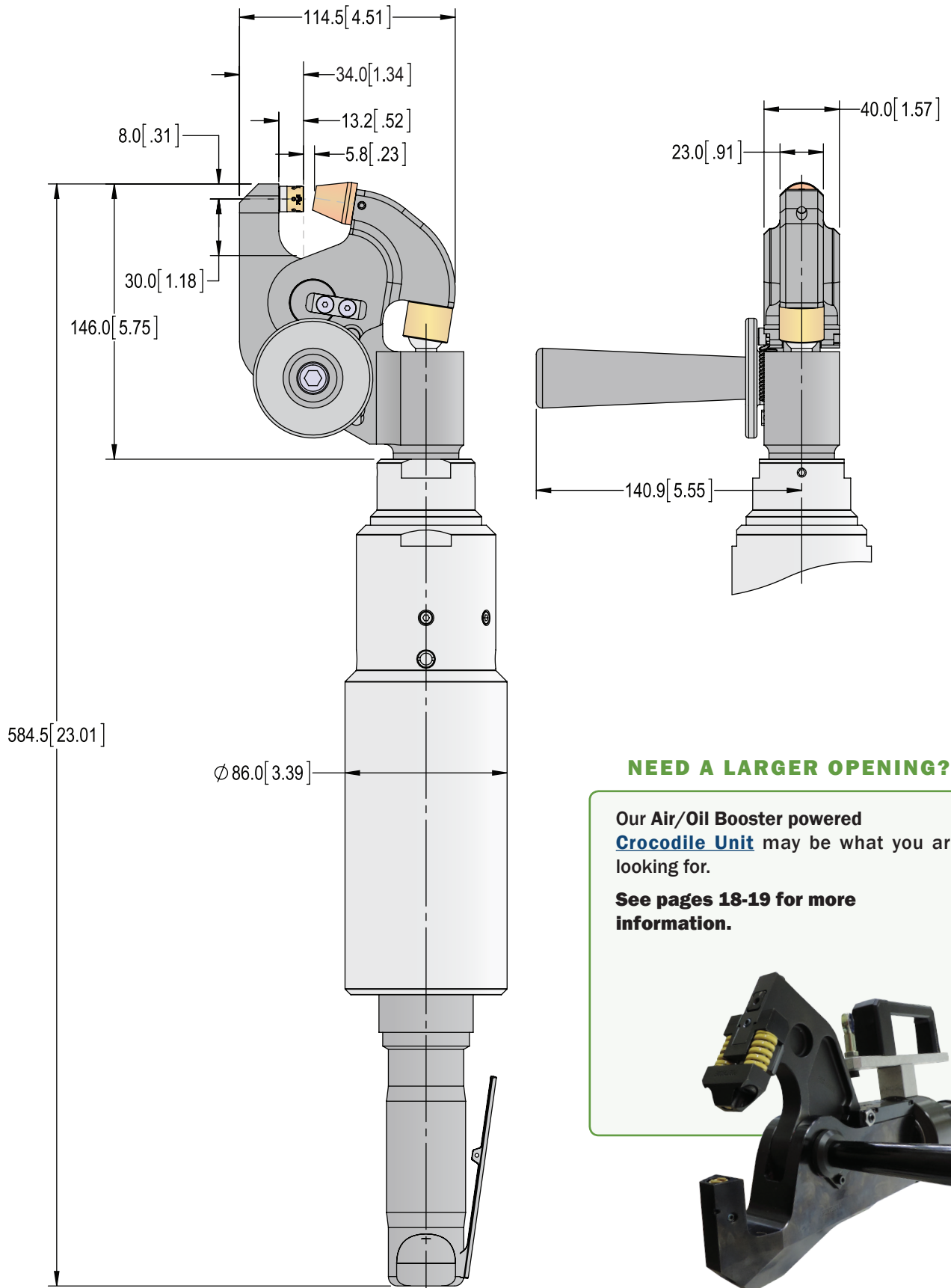

NEED A LARGER OPENING?

Our Air/Oil Booster powered **Crocodile Unit** may be what you are looking for.

See pages 18-19 for more information.



LIT-L-LOC UNITS

BTM's Lit-L-Loc units are an economical approach to fastening sheet metal assemblies with edge or upstanding flanges.

The punch and die can be reversed in these units, allowing the Tog-L-Loc® or Lance-N-Loc™ “button” to form on either side of assembled parts.

These units may be purchased separately or as a complete kit which includes a booster and two meter hose assembly.



www.btmcomp.com/lit-l-loc-units.html

LIT-L-LOC UNITS ARE BEST WHEN:

- *Joining edge flanges and standing flanges.*
- *A compact unit will provide easier access to the joint location.*
- *Joining thicker material with larger clinch joints is required.*

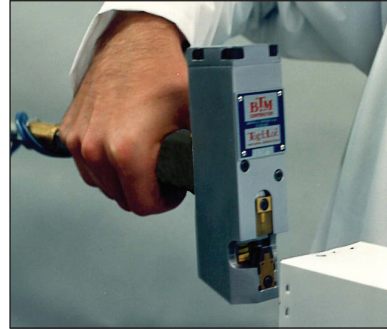

Use With BTM's
15cc Booster



(See page 20)

Opening	6mm [.25"]
Trigger Type	Single
Maximum Operating Pressure	345 BAR [5000 PSI]
Cycle Time	1 second
Maximum Combined Material Thickness that can be joined with these units	2mm [.08"]

Clinch Joint Type*	Tog-L-Loc® or Lance-N-Loc™	
Tool Size(s)	3.0	4.6
Max. Anvil Depth	.035	.040

TYPICAL APPLICATIONS FOR A LIT-L-LOC UNIT:

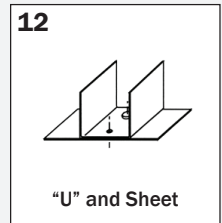
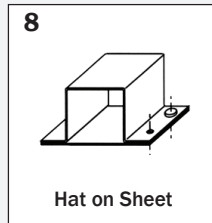
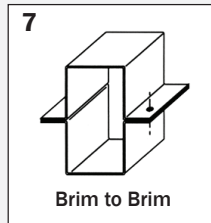
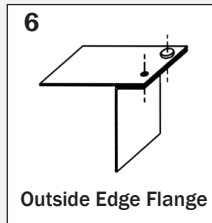
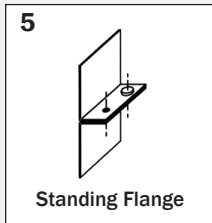
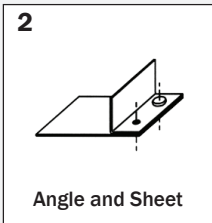

HOW TO ORDER



It is recommended that you [contact a BTM sales engineer](#) prior to purchasing a handheld unit to determine the optimal tooling configuration for your application.

Email info@btm-europe.de to request a quote!

Complete System SEE PAGE 11 Includes: <ul style="list-style-type: none"> • A Lit-L-Loc unit • Two sets of Tooling • 15cc booster (PD238100A) • 3 meter hose assembly (711100C) <i>Not Included: Spring Balancer</i>	OR	Individual Unit SEE PAGE 11 Includes two sets of Tooling.	Hose Assembly 3 Meter [10 Foot] Hose 711100C	Booster 15cc Booster (See page 20) PD238100A	Spring Balancer Varies Per Unit (See page 11)
--	-----------	---	--	--	---

STANDARD LIT-L-LOC UNITS

	3.0 Tooling Unit	4.6 Tooling Unit
Throat Depth	6.2mm [.24"]	7.0mm [.28"]
Unit Weight	2.6 kg [5.7 lbs]	3.0 kg [6.7 lbs]

BTM NUMBERS	3.0 Tooling Unit	4.6 Tooling Unit
Complete Kit	014334	PD227100A
Unit Only	014097	PD224500A
Spring Balancer 2.6-3.8 kg [5.73-8.38 lbs]	052945	

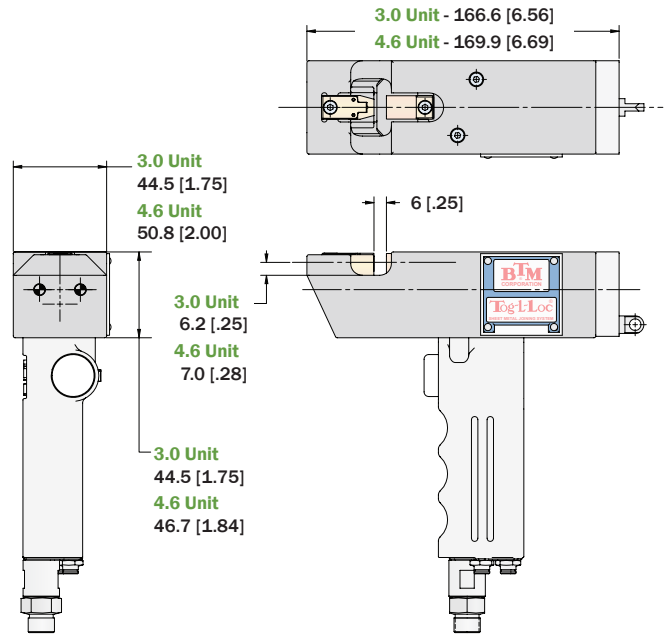

DEEP THROAT LIT-L-LOC UNIT

Throat Depth	38.1mm [1.50"]
Unit Weight	4.6 kg [10 lbs]

BTM NUMBER	
Complete Kit	PD227200A
Unit Only	PD224600A
Spring Balancer 4-7 kg [10-15 lbs]	052937

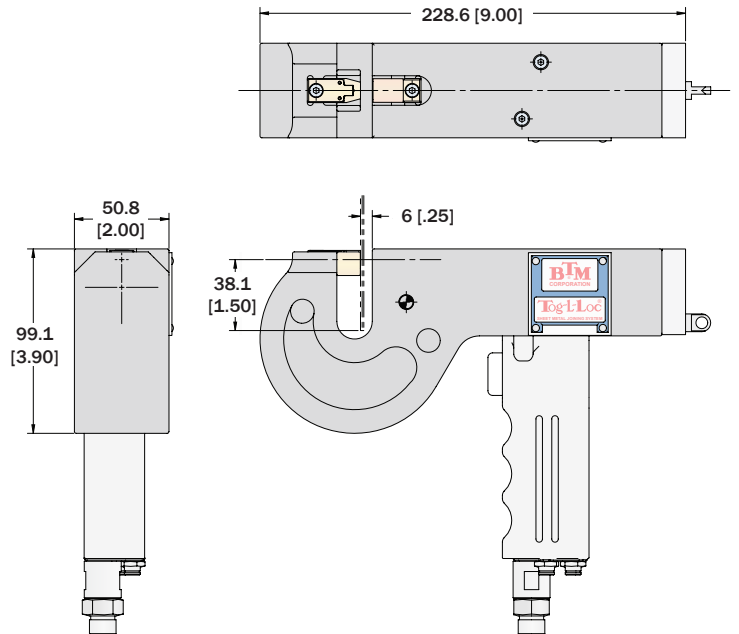

DEEPER THROAT LIT-L-LOC UNIT

Throat Depth	76.2mm [3.00"]
Unit Weight	10.6 kg [23.4 lbs]

BTM NUMBER	
Complete Kit	PD227300A
Unit Only	PD224700A
Spring Balancer 9-14 kg [20-30 lbs]	024049

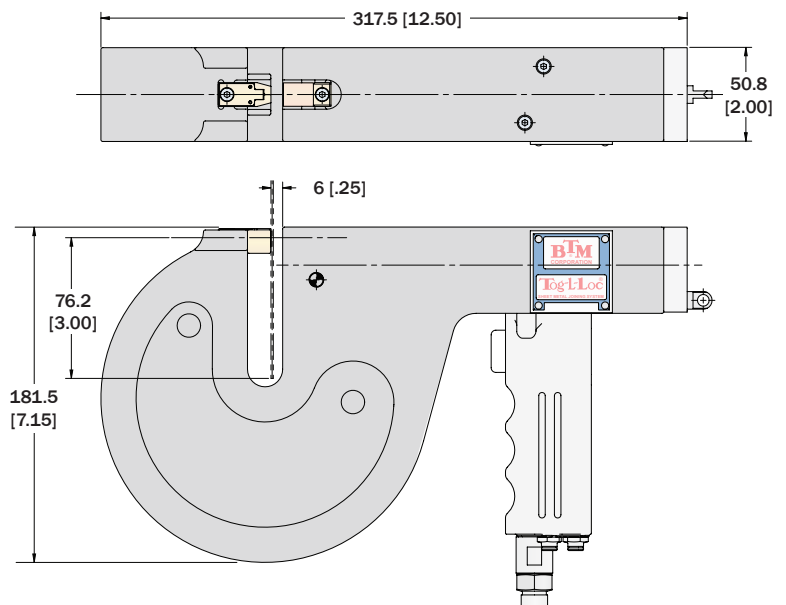

DUROLOC7 UNIT

The Duroloc7 clinching unit features easy to adjust shut height and interchangeable anvils. Shut height cartridges easily swap to accommodate required material thickness ranges. Interchangeable anvils accommodate a wider range of part cross sections than the Lit-L-Loc unit.

Duroloc7 units are sold separately or as a complete system including a hose and air/oil booster.

Hangers and balancers are also available for assisting operator productivity.



www.btmcomp.com/duroloc7-units.html

A DUROLOC7 UNIT IS BEST WHEN:

- More tooling options are required vs. a Lit-L-Loc Unit.
- The part being joined has a small lip, or flange.



(Unit Shown with optional 360° Hanger.)



Use With BTM's
15cc Booster

(See page 20)

Opening	6mm [.25"]
Throat Depth	38mm [1.50"]
Trigger Type	Single
Maximum Operating Pressure	345 BAR [5000 PSI]
Cycle Time	1 second
Unit Weight	5.6 kg [12.4 lbs]
Maximum Combined Material Thickness that can be joined with this unit	2mm [.08"]

Clinch Joint Type	Round	
Tool Size(s)	3.8	4.6

TYPICAL APPLICATIONS FOR A DUROLOC7 UNIT:

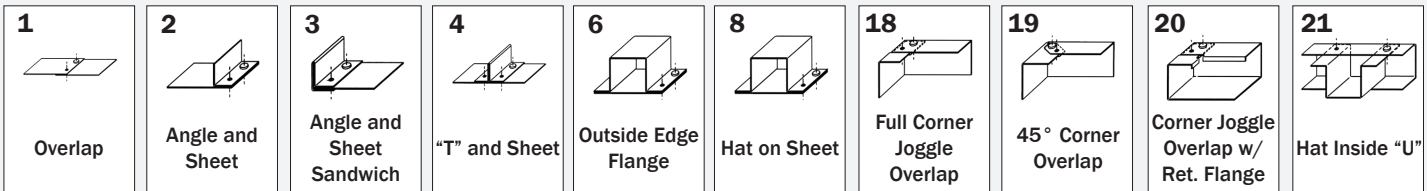

HOW TO ORDER



It is recommended that you [contact a BTM sales engineer](#) prior to purchasing a handheld unit to determine the optimal tooling configuration for your application.

Email info@btm-europe.de to request a quote!

Complete System PD296200A Includes: <ul style="list-style-type: none"> • A Duroloc7 unit (PD281500A) • Two sets of Tooling • 15cc booster (PD238100A) • 3 meter hose assembly (711100C) <i>Not Included: Spring Balancer</i>	OR	Individual Unit PD281500A Includes two sets of Tooling	Hose Assembly 3 Meter [10 Foot] Hose 711100C	Booster 15cc Booster (See page 20) PD238100A	Optional Rotation Hanger 360° Hanger (See page 34) PD281500J OR 180° Hanger (See page 34) PD281500R	Spring Balancer 6-10 kg [13.3-22 lbs] (Unit or Unit + 360° Hanger) 051898 OR 9-14 kg [20-30 lbs] (Unit + 180° Hanger) 024049
---	----	--	--	---	---	--

DUROLOC7 UNIT

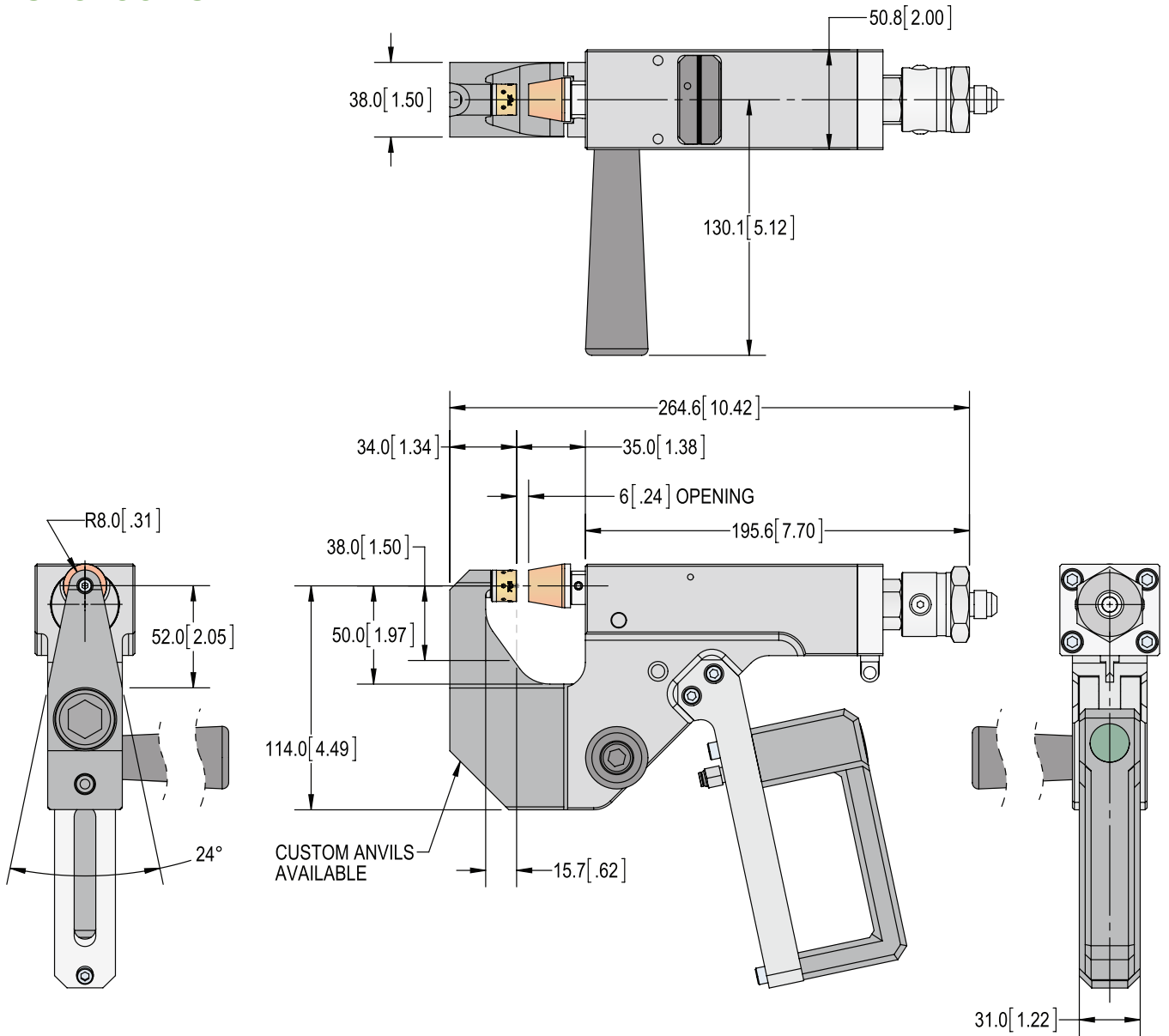

OPTIONAL ROTATION HANGERS

360° HANGER

This hanger allows a Duroloc7 Unit to rotate a full 360° on a single axis.

(See page 34)

Weight (without Unit)	0.37 kg [0.82 lbs]
---------------------------------	-----------------------

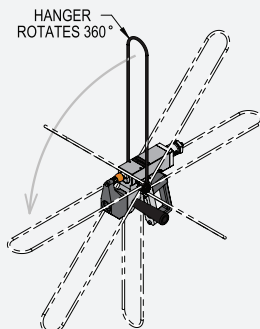

180° HANGER

This hanger allows a Duroloc7 Unit to rotate 180° on a single axis. (See page 34)

Weight (without Unit)	3.4 kg [7.5 lbs]
---------------------------------	------------------

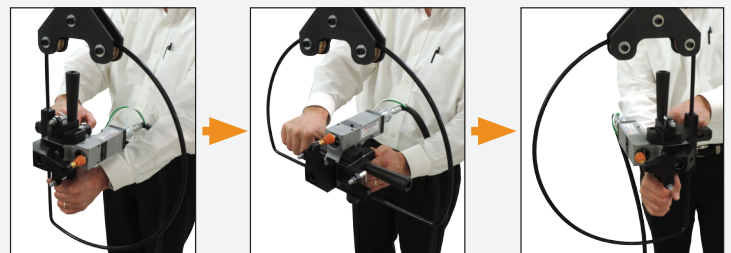

BAYONET UNIT

BTM's Bayonet units open easily to reach over part cross sections then quickly close and mechanically interlock for safe operation.

The unit opens to 47.5mm [1.87in] and then is manually closed for a safe opening of 6mm [.25in] opening. The unit will not operate unless it is in the closed and locked working position for operator safety. The operator can then use the other hand to hold or position the parts.

The Bayonet unit is driven by an air/oil booster which requires 80psi [5.5 bar] compressed air. Special "C" frames are also available. The Punch & the Die are also reversible.



Use With BTM's
15cc Booster

(See page 20)



www.btmcomp.com/bayonet-units.html

A BAYONET UNIT IS BEST WHEN:

- A larger opening is required to gain access to a joint location.
- A flange with a return is being joined.

Opening	6mm [.25"] (Working) 47.5mm [1.87"] (Full Open)
Throat Depth	50mm [2.00"]
Trigger Type	Single
Maximum Operating Pressure	345 BAR [5000 PSI]
Cycle Time	1.5 seconds
Unit Weight	6 kg [13.2 lbs]
Maximum Combined Material Thickness that can be joined with this unit	3mm [.12"]

Clinch Joint Type	Round		
Tool Size(s)	3.0	3.8	4.6

TYPICAL APPLICATIONS FOR A BAYONET UNIT:

1 Overlap	2 Angle and Sheet	3 Angle and Sheet Sandwich	4 "T" and Sheet	6 Outside Edge Flange	8 Hat on Sheet	18 Full Corner Joggle Overlap	19 45° Corner Overlap	20 Corner Joggle Overlap w/ Ret. Flange	21 Hat Inside "U"
-------------------------	---------------------------------	--	-------------------------------	-------------------------------------	------------------------------	---	-------------------------------------	---	---------------------------------

HOW TO ORDER



It is recommended that you [contact a BTM sales engineer](#) prior to purchasing a handheld unit to determine the optimal tooling configuration for your application.

Email info@btm-europe.de to request a quote!

Complete System 711200C A Complete System Includes: <ul style="list-style-type: none"> • A Bayonet unit (711200F) • Two sets of Tooling • 15cc booster (PD238100A) • 3 meter hose assembly (711100C) <i>Not Included: Spring Balancer</i>	OR	Individual Unit 711200F Includes two sets of Tooling	Hose Assembly 3 Meter [10 Foot] Hose 711100C	Booster 15cc Booster (See page 20) PD238100A	Spring Balancer 6-10 kg [13.3-22 lbs] 051898
--	-----------	--	---	--	---

BAYONET UNIT

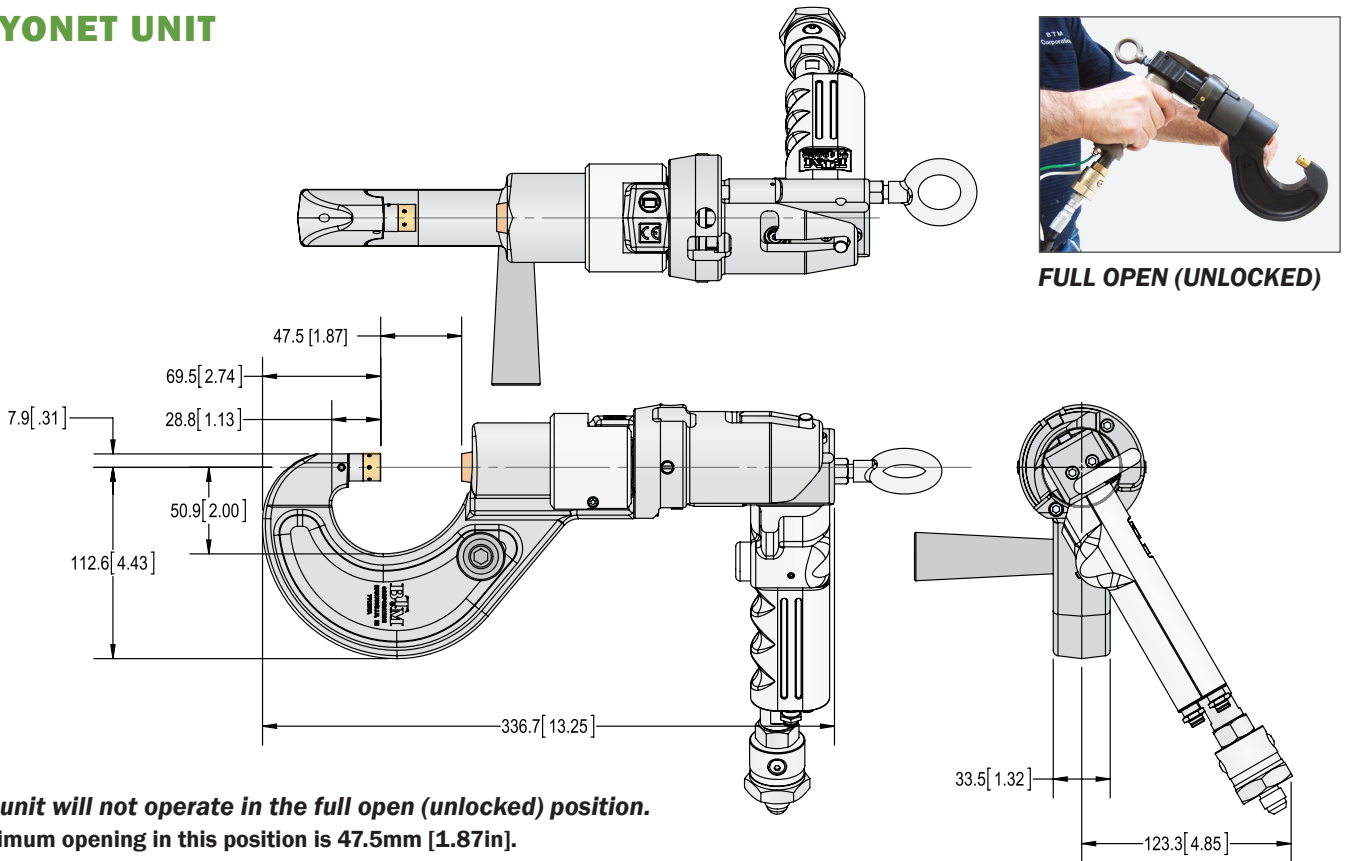

The unit will not operate in the full open (unlocked) position. Maximum opening in this position is 47.5mm [1.87in].



WORKING (LOCKED)

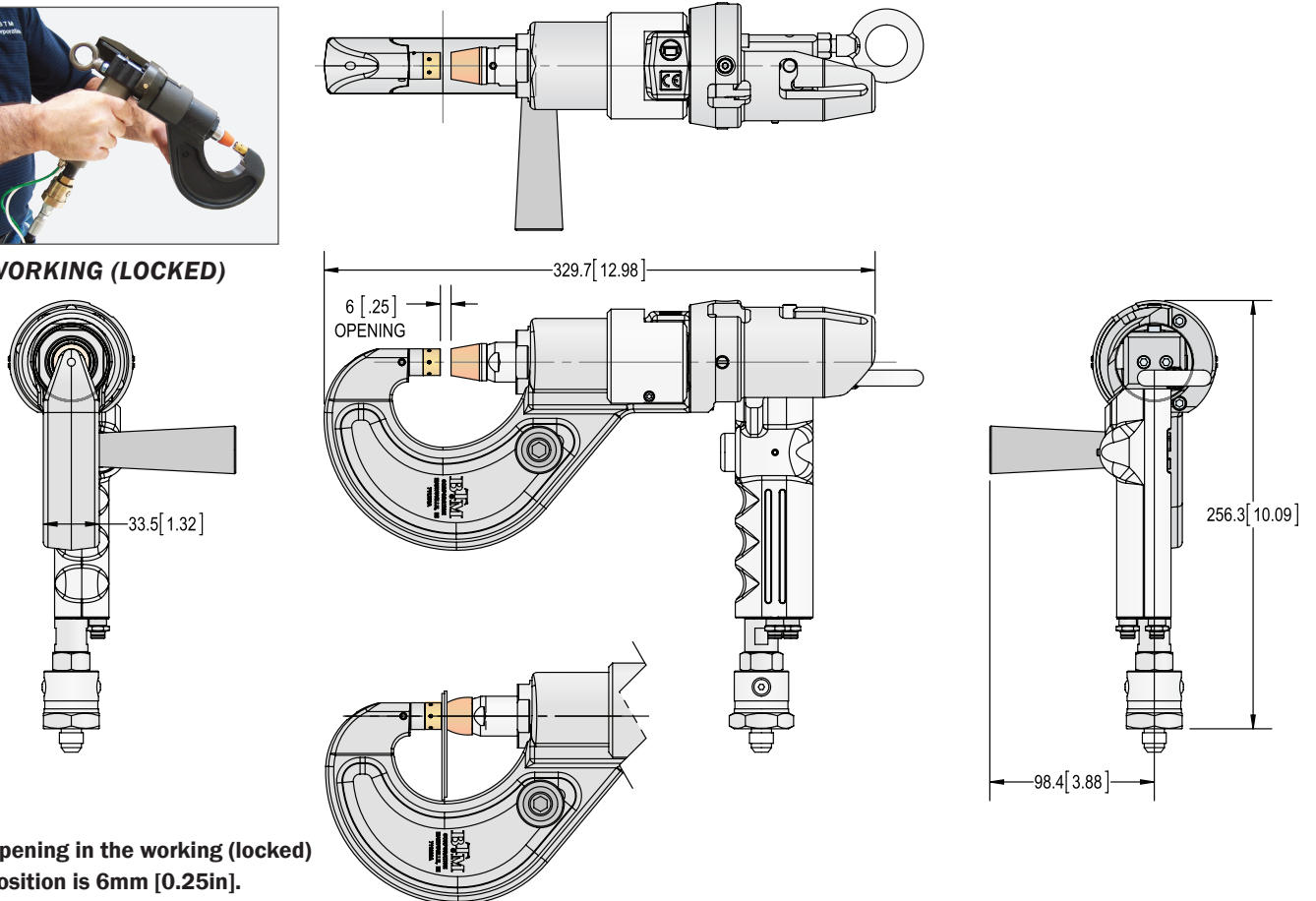

Opening in the working (locked) position is 6mm [0.25in].

ADAPTABLE BAYONET UNIT

The Adaptable Bayonet Unit uses the basic components of our popular standard bayonet unit but allows you to inexpensively determine the “C” frame and tool holder designs to accommodate your part(s).

Tell us the basic dimensions required as shown on the next page, or show us your part drawing and we will provide you with a quote for a complete unit. You can also purchase just the cylinder sub-assembly, clinch tooling, hose and booster then design, build and assemble the “C” frame and tool holder yourself. You can also contact our sales department for assistance.



www.btmcomp.com/bayonet-units.html

AN ADAPTABLE BAYONET UNIT IS BEST WHEN:

- A standard Bayonet Unit cannot clear the part.
- A joint location is inaccessible by standard units.



Use With BTM's
15cc Booster



(See page 20)

Opening	6.0mm [.25"] (Working) 47.5mm [1.87"] (Full Open)
Throat Depth	Customer Specified
Trigger Type	Single
Maximum Operating Pressure	345 BAR [5000 PSI]
Cycle Time	1.5 seconds
Unit Weight	Varies
Maximum Combined Material Thickness that can be joined with this unit	3mm [.12"]

Clinch Joint Type	Round or Lance-N-Loc™		
Tool Size(s)	3.0	3.8	4.6

TYPICAL APPLICATIONS FOR AN ADAPTABLE BAYONET UNIT:

1 Overlap	2 Angle and Sheet	3 Angle and Sheet Sandwich	4 “T” and Sheet	6 Outside Edge Flange	8 Hat on Sheet	18 Full Corner Joggle Overlap	19 45° Corner Overlap	20 Corner Joggle Overlap w/ Ret. Flange	21 Hat Inside “U”
-------------------------	---------------------------------	--	-------------------------------	-------------------------------------	------------------------------	---	-------------------------------------	---	---------------------------------

HOW TO ORDER



It is recommended that you [contact a BTM sales engineer](#) prior to purchasing a handheld unit to determine the optimal tooling configuration for your application.

Email info@btm-europe.de to request a quote!

Individual Unit Contact BTM email: info@btm-europe.de Includes Two sets of Tooling	Hose Assembly 3 Meter [10 Foot] Hose 711100C	Booster 15cc Booster (See page 20) PD238100A	Spring Balancer Depends on Unit Weight (Contact BTM)
---	--	---	---

ADAPTABLE BAYONET UNIT

You can configure an adaptable bayonet unit to suit the accessibility requirements of your parts. The drawing below indicates the basic dimensions required. There are limitless configuration possibilities. Please provide a copy of this catalog page with the dimensions you require and we will provide you with a price quote. To speed the process, email a drawing of the parts you want to join indicating the joint locations.

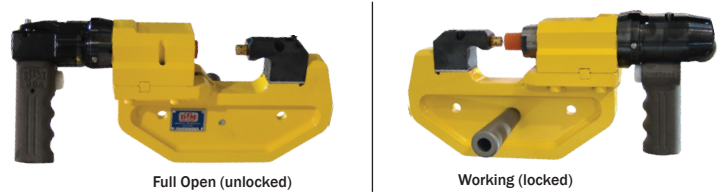

This unit features the same action as the Standard Bayonet.

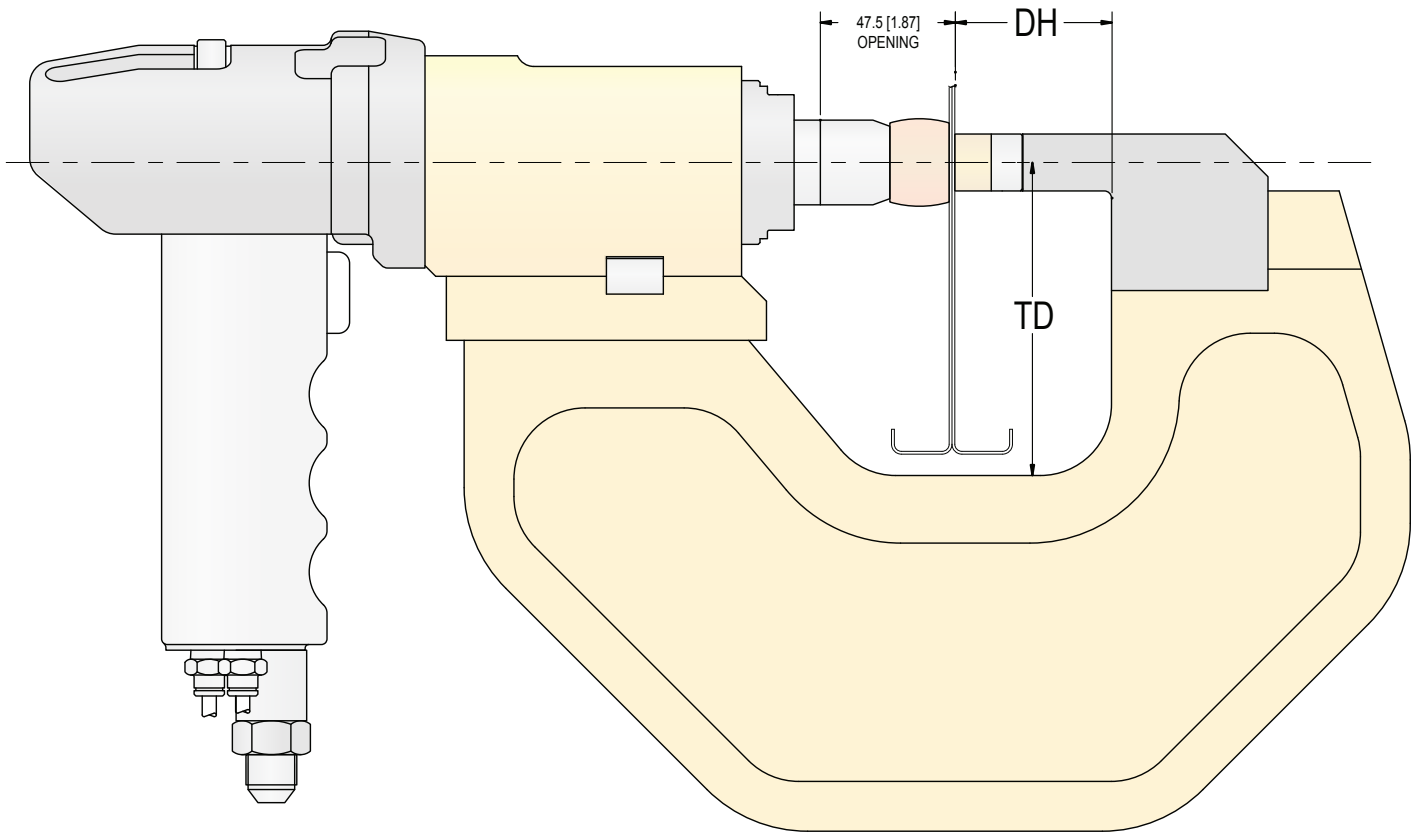

PLEASE SPECIFY:

Throat Depth (TD)

Die Height (DH)
Standard: 40mm [1.57"], 60mm [2.36"], 80mm [3.15"], or 100mm [3.94"]

Learn more online at: www.btmcomp.com/bayonet-units.html
 or send us an email at info@btm-europe.de

CROCODILE UNIT

BTM's Crocodile Unit was designed especially for clinching HVAC ducting. The unit opens and closes easily to reach over the ductwork flange and is quick cycling.

The integrated rotary suspension makes it easy to move around corners through a full 360° without twisting the hydraulic and pneumatic control hoses increasing productivity. The rotary suspension is equipped with detents every 90° for easy alignment with horizontal and vertical joining surfaces. The Crocodile unit will also clinch upstanding flanges where there is a return flange.

The Crocodile unit joins thicker material with larger joints than the UniCroc and is well suited for small to medium size production runs.



www.btmcomp.com/crocodile-units.html

A CROCODILE UNIT IS BEST WHEN:

- You are joining over a flange on a part.
- Your part needs joints in various orientations.



Use with BTM's
49cc Booster



(See page 21)

Part Load Opening	41.0mm [1.61"]
Power Stroke Opening	6.0mm [.24"]
Throat Depth	50mm [2.00"]
Trigger Type	Single
Maximum Operating Pressure	345 BAR [5000 PSI]
Cycle Time	1.5 sec.
Unit Weight	8.8 kg [19.5 lbs]
Maximum Combined Material Thickness that can be joined with this unit	3mm [.12"]

Clinch Joint Type*	Round	Geo-Clinch®
Tool Size(s)	3.8, 4.6	3.0, 3.8

TYPICAL APPLICATIONS FOR A CROCODILE UNIT:

1 Overlap	2 Angle and Sheet	3 Angle and Sheet Sandwich	4 "T" and Sheet	6 Outside Edge Flange	8 Hat on Sheet	17 Two Piece Full Corner Overlap	18 Full Corner Joggle Overlap	19 45° Corner Overlap
-------------------------	---------------------------------	--	-------------------------------	-------------------------------------	------------------------------	--	---	-------------------------------------

HOW TO ORDER



It is recommended that you [contact a BTM sales engineer](#) prior to purchasing a handheld unit to determine the optimal tooling configuration for your application.

Email info@btm-europe.de to request a quote!

Complete System	Individual Unit	Hose Assembly	Booster	Optional Vertical Hanger	Spring Balancer
PD279800F A Complete System Includes: • A Crocodile unit (PD279800A) • Two sets of Tooling • 49cc booster (PD237600A) • 3 meter hose assembly (711100C) Not Included: Spring Balancer	OR PD279800A Includes two sets of Tooling	3 Meter [10 Foot] Hose 711100C	49cc Booster (See page 21) PD237600A	PD279800G (See page 19)	6-10 kg [13.3-22 lbs] 051898

CROCODILE UNIT



“Jaw” is manually opened and closed.

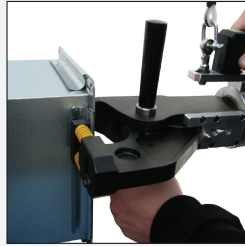

“Head” can be manually rotated 360°

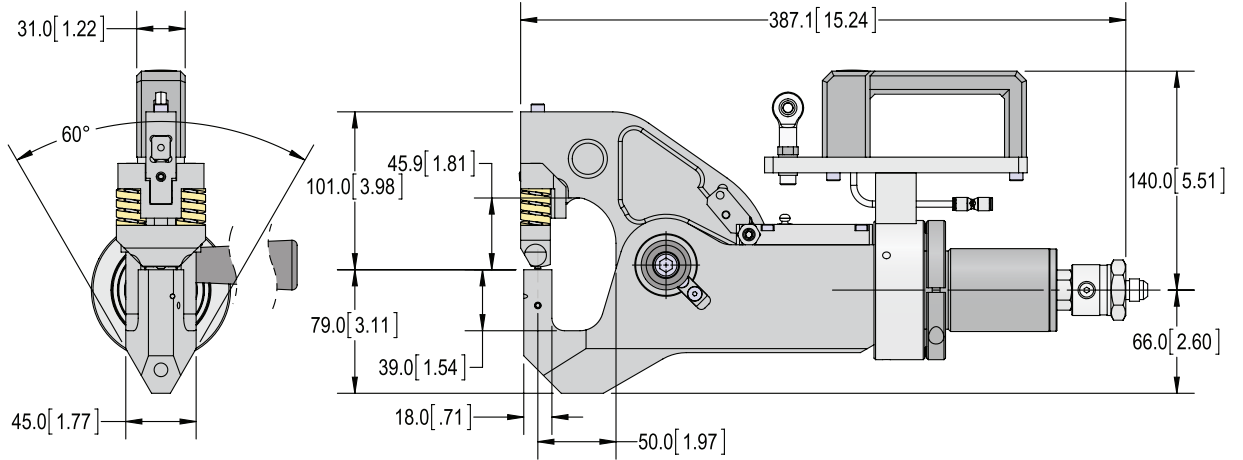
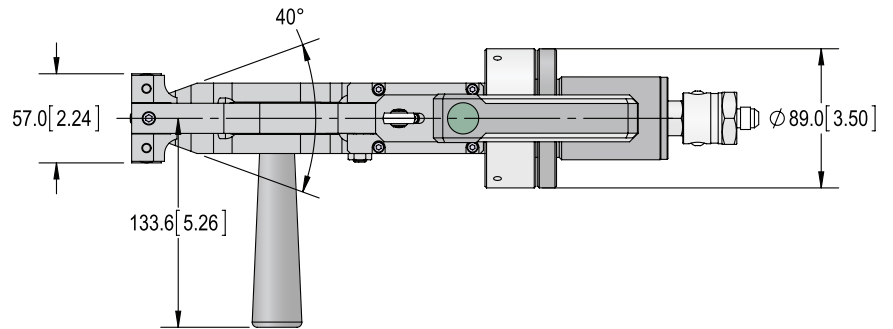

OPTIONAL VERTICAL HANGER

Offering an operator easy positioning for vertical clinch joining.

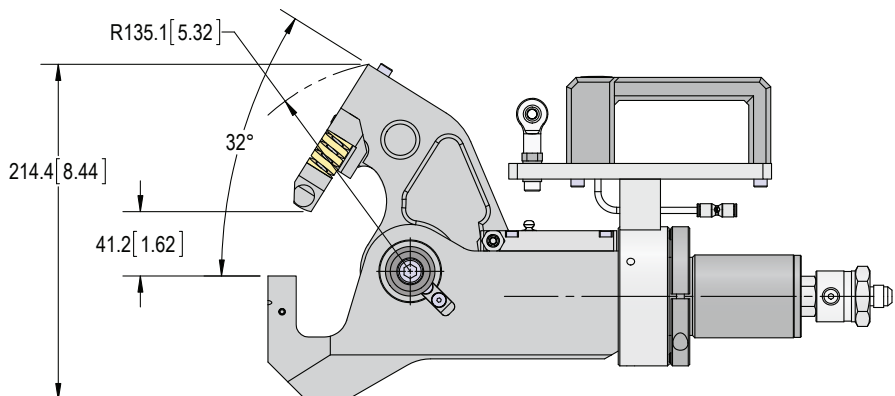
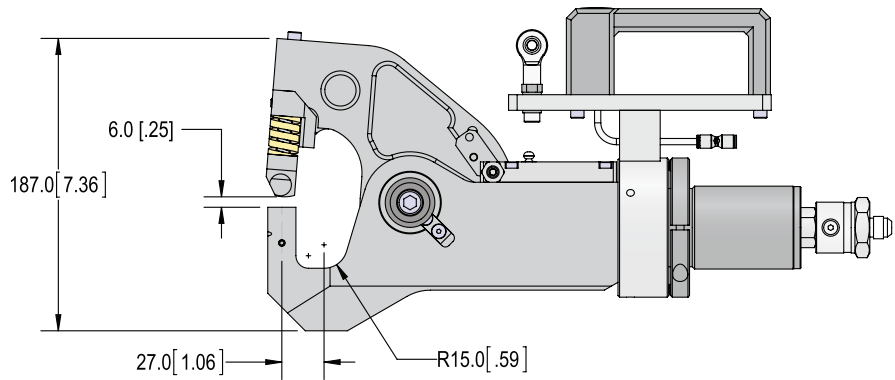
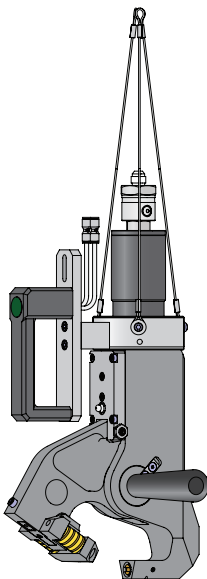

15CC AIR/OIL BOOSTER

A self-contained power package that requires only one pneumatic supply line.

Booster Ratio	61:1
Weight (without hose)	8.2kg [18 lbs]
Maximum Intensified Volume	15.4cc [.94 cu. in]
Maximum Output	337 BAR [4880 PSI] @ 5.5 BAR [80 PSI]

Air Pressure In		Hydraulic Pressure Out	
BAR	PSI	BAR	PSI
2.8	40	168	2440
3.4	50	210	3050
4.1	60	252	3660
4.8	70	294	4270
5.5	80	337	4880

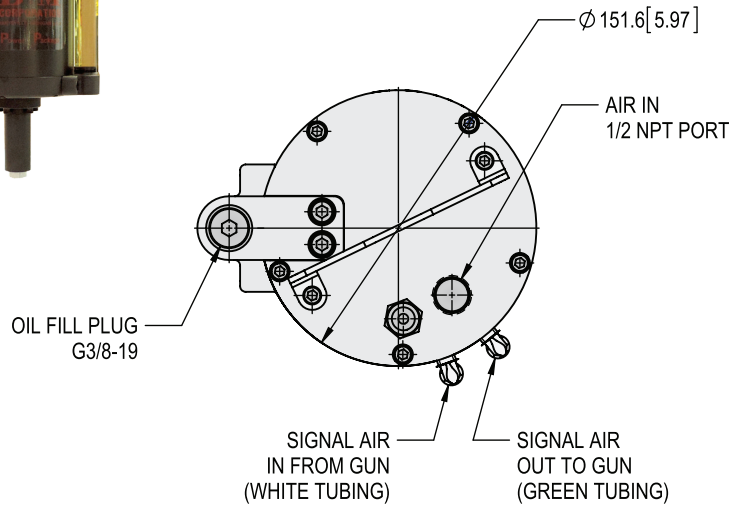

UNIT COMPATIBILITY



Lit-L-Loc Units
(See page 10)

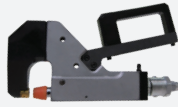

Duroloc7
(See page 12)



Bayonet Units
(See page 14)

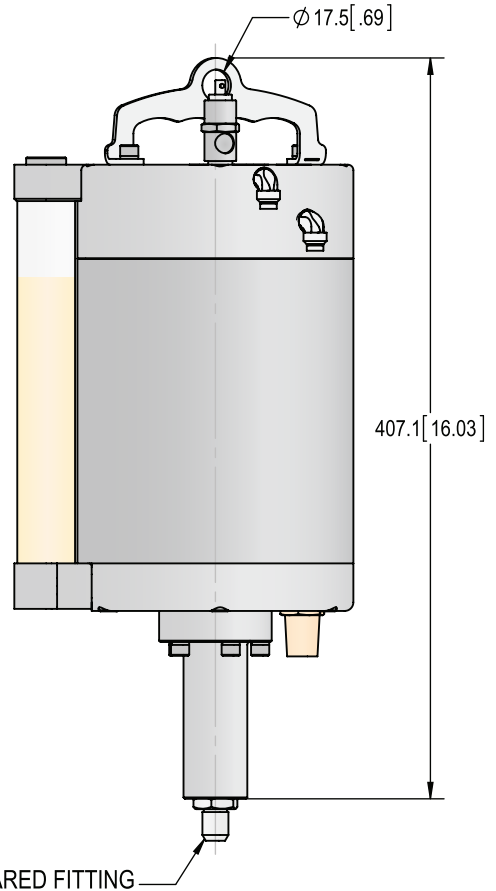

HOW TO ORDER

Call +1-810-364-4567,
or email info@btm-europe.de to request a quote!

BTM NUMBER

PD238100A

NOTE: HOSE ASSEMBLY NOT INCLUDED.

49CC AIR/OIL BOOSTER

Features more volume than our 15cc Booster.
This booster can power our Crocodile unit.

Booster Ratio	64:1
Weight (without hose)	17.8kg [39 lbs]
Maximum Intensified Volume	49cc [3.0 cu. in]
Maximum Output	353 BAR [5120 PSI] @ 5.5 BAR [80 PSI]

Air Pressure In		Hydraulic Pressure Out	
BAR	PSI	BAR	PSI
4.1	60	264.8	3840
4.8	70	308.9	4480
5.2	75	330.9	4800
5.5	80	353.0	5120

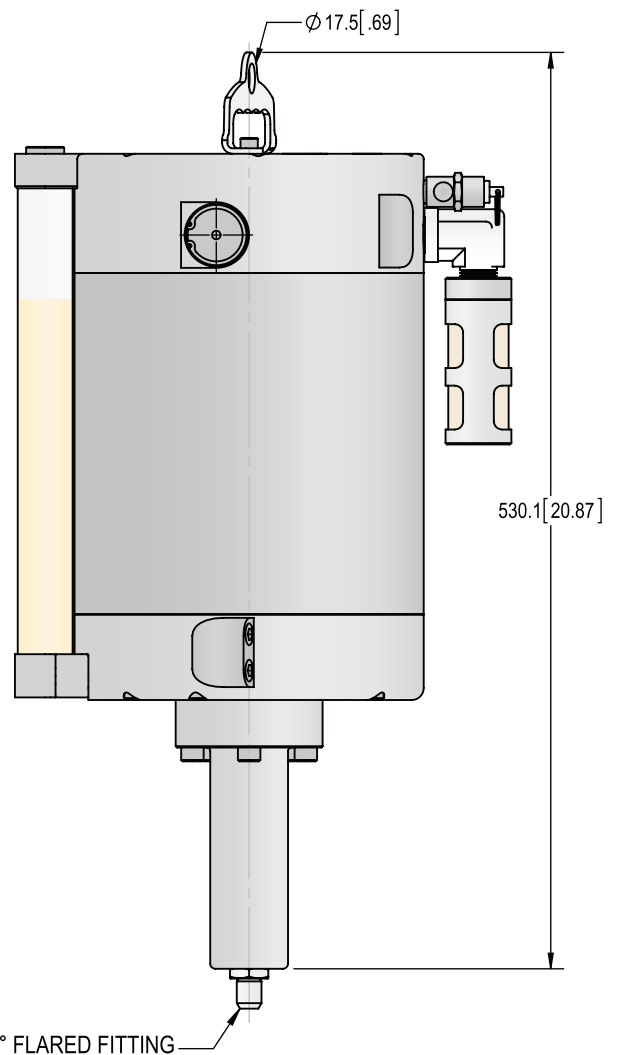
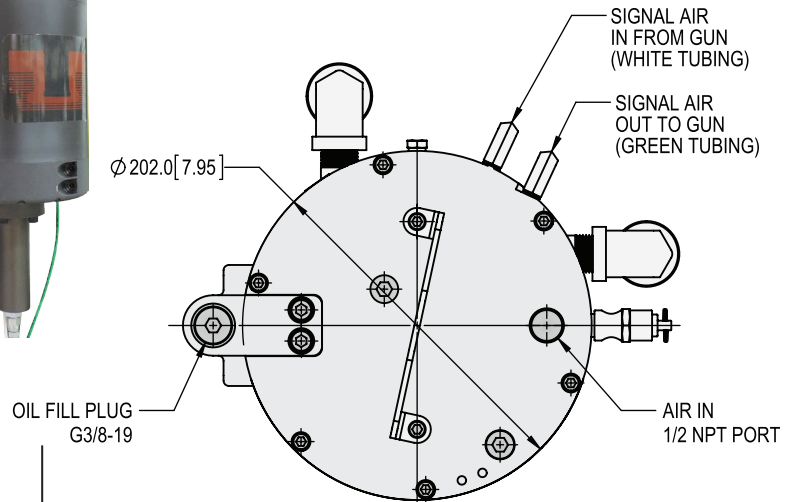

UNIT COMPATIBILITY



Crocodile Unit
(See page 18)



Lit-L-Loc Units
(See page 10)

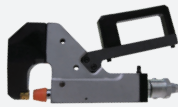

Duroloc7
(See page 12)



Bayonet Units
(See page 14)

HOW TO ORDER

Call +1-810-364-4567,
or email info@btm-europe.de to request a quote!

BTM NUMBER

PD237600A

NOTE: HOSE ASSEMBLY NOT INCLUDED.

7006 UNIT

These hydraulic hand operated units are most commonly used for prototyping & small to medium production runs. A standard 7006 Unit is available in one of two different anvil styles (the style of anvil required depends on the design of part being joined).

These units feature a dual handled design with two operation triggers. Both triggers must be pressed in order to open, close, and cycle the unit.



www.btmcomp.com/7006-units.html

THE 7006 UNIT IS BEST WHEN:

- You need more force than booster units provide.
- You want a compact unit for easier positioning.

Opening	32mm [1.26"]
Stroke	35mm [1.38"]
Peck Stroke	6mm [.25"]
Throat Depth	50mm [1.97"]
Trigger Type	Dual
Operating Pressure	175 BAR [2500 PSI]
Cycle Time	2 seconds
Unit Weight	11.3kg [25lbs]
Maximum Combined Material Thickness that can be joined with this unit	4mm [.16"]

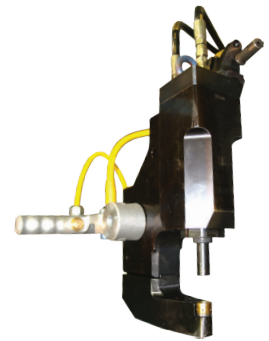

Use with Hydraulic Pump



(See page 28)

Clinch Joint Type	Round		
Tool Size(s)	3.0	3.8	4.6

TYPICAL APPLICATIONS FOR A 7006 UNIT:

<p>1</p> <p>Overlap</p>	<p>2</p> <p>Angle and Sheet</p>	<p>4</p> <p>"T" and Sheet</p>	<p>6</p> <p>Outside Edge Flange</p>	<p>8</p> <p>Hat on Sheet</p>	<p>9</p> <p>"U" and Sheet</p>	<p>12</p> <p>Square Tube and Sheet</p>
<p>17</p> <p>Two Piece Full Corner Overlap</p>	<p>18</p> <p>Full Corner Joggle Overlap</p>	<p>19</p> <p>45° Corner Overlap</p>	<p>20</p> <p>Corner Joggle Overlap w/ Ret. Flange</p>	<p>21</p> <p>Hat Inside "U"</p>		

HOW TO ORDER



It is recommended that you [contact a BTM sales engineer](#) prior to purchasing a handheld unit to determine the optimal tooling configuration for your application.

Email info@btm-europe.de to request a quote!

<p>Individual Unit</p> <p>SEE PAGE 23</p>	<p>Hydraulic Pump</p> <p>HydroPak1 (See page 28) 3001800A</p>	<p>Hose Assembly</p> <p>3.7 Meter [12 Foot] 015444A</p> <p>OR</p> <p>6.1 Meter [20 Foot] 030542A</p> <p>OR</p> <p>7.3 Meter [24 Foot] 030543A</p>	<p>Optional Gimbal Mount</p> <p>Allows 360° rotation on 3 axis (See page 34) 700600G</p>	<p>Spring Balancer</p> <p>9-14 kg [20-30 lb] (For 7006 Unit Only) 024049</p> <p>OR</p> <p>13-17 kg [29-37 lb] (For 7006 Unit + Gimbal Mount) 024050</p>
---	--	--	--	---

7006 UNIT

USING THE UNIT

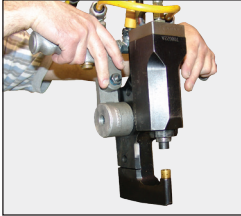

Both triggers must be depressed to close the unit and operate the peck cycle.

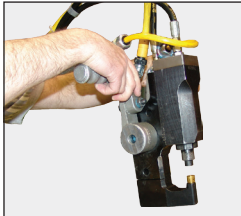

The peck cycle feature allows joints to be created faster.

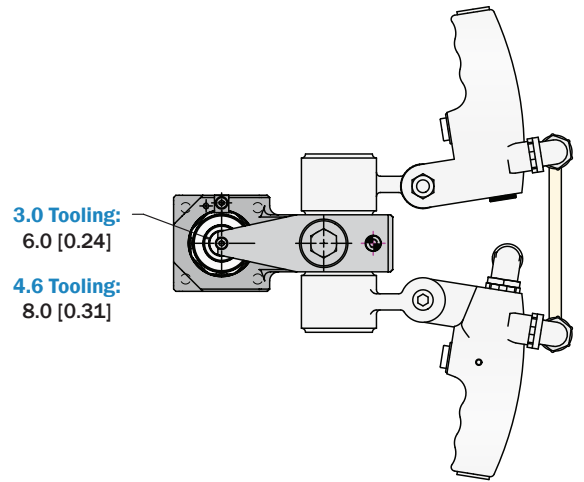
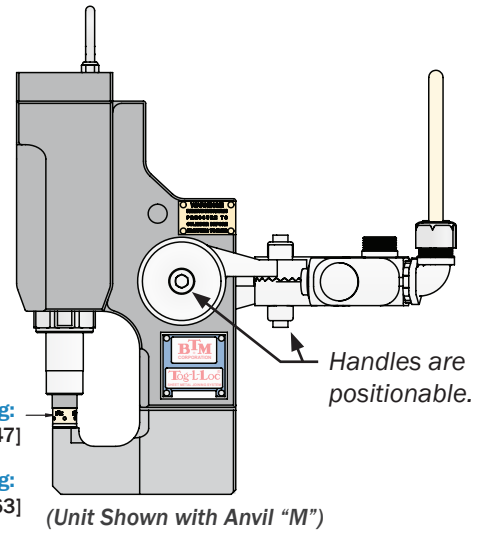
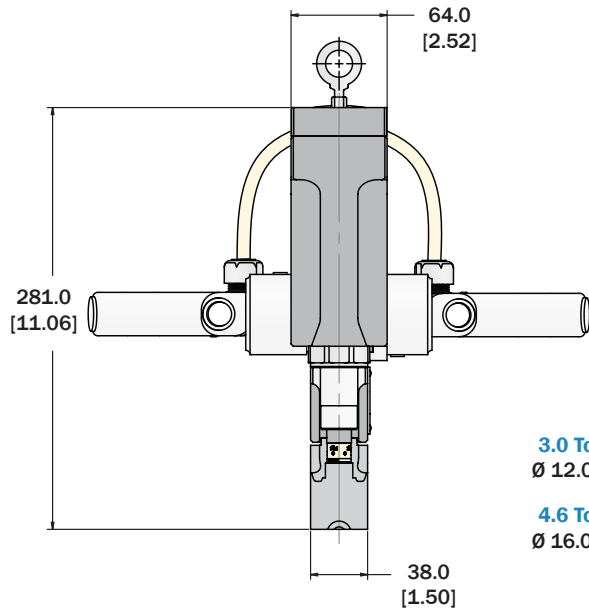
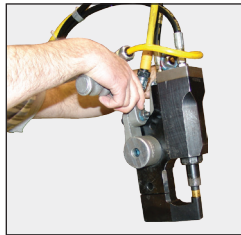
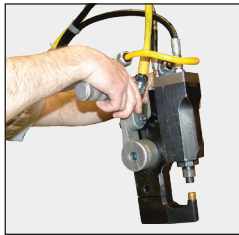
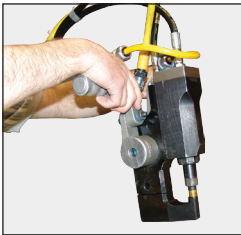

7006 UNIT ANVILS

ANVIL "M"

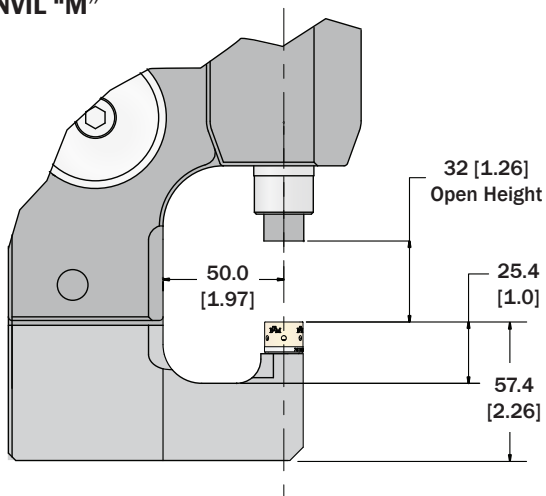

BTM NUMBER	
7006 Unit with Anvil "M"	700600M

ANVIL "N"

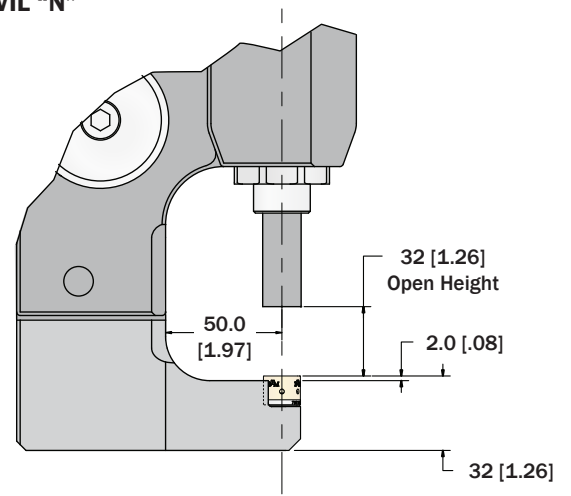

BTM NUMBER	
7006 Unit with Anvil "N"	700600N

HEAVY DUTY 7006 UNIT

These hydraulic hand operated units are most commonly used for prototyping & small to medium production runs.

A standard Heavy Duty 7006 Unit is available in one of two different anvil styles (the style of anvil required depends on the design of part being joined).

This unit is designed to operate with 5.5 size tooling.



www.btmcomp.com/7006-units.html

THE HEAVY DUTY 7006 UNIT IS BEST WHEN:

- 5.5 size round tooling is required.

Opening	32mm [1.26"]
Stroke	35.0mm [1.38"]
Peck Stroke	6mm [.25"]
Throat Depth	75mm [2.95"]
Trigger Type	Dual
Operating Pressure	175 BAR [2500 PSI]
Cycle Time	2 sec.
Unit Weight	22-24kg [49-53lbs]
Maximum Combined Material Thickness that can be joined with this unit	4mm [.16"]

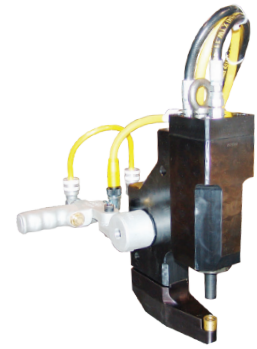

Use with Hydraulic Pump



(See page 28)

Clinch Joint Type*	Round
Tool Size(s)	5.5

TYPICAL APPLICATIONS FOR A 7006 UNIT:

1 Overlap	2 Angle and Sheet	4 "T" and Sheet	6 Outside Edge Flange	8 Hat on Sheet	9 "U" and Sheet	12 Square Tube and Sheet
17 Two Piece Full Corner Overlap	18 Full Corner Joggle Overlap	19 45° Corner Overlap	20 Corner Joggle Overlap w/ Ret. Flange	21 Hat Inside "U"		

HOW TO ORDER



It is recommended that you [contact a BTM sales engineer](#) prior to purchasing a handheld unit to determine the optimal tooling configuration for your application.

Email info@btm-europe.de to request a quote!

Individual Unit SEE PAGE 25	Hydraulic Pump HydroPak1 (See page 28) 3001800A	Hose Assembly 3.7 Meter [12 Foot] 015444A OR 6.1 Meter [20 Foot] 030542A OR 7.3 Meter [24 Foot] 030543A	Optional Gimbal Mount Allows 360° rotation on 3 axis (See page 34) 792100G	Spring Balancer 20-30 kg [44-66 lb] (For Heavy Duty 7006 Unit Only) 025900 OR 30-45 kg [66-99 lb] (For Heavy Duty 7006 Unit + Gimbal) 034426
---	---	--	--	--

HEAVY DUTY 7006 UNIT

USING THE UNIT

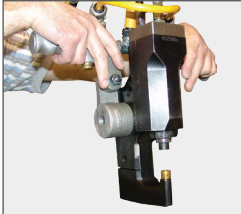

Both triggers must be depressed to close the unit and operate the peck cycle.

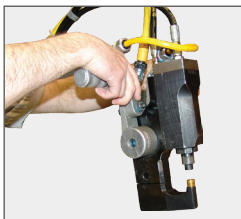

The peck cycle feature allows joints to be created faster.

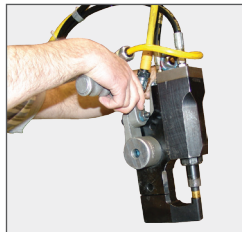
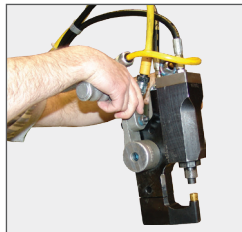
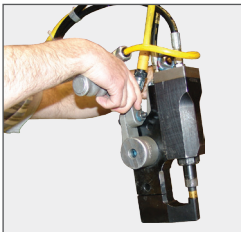

(Standard 7006 Unit Shown)

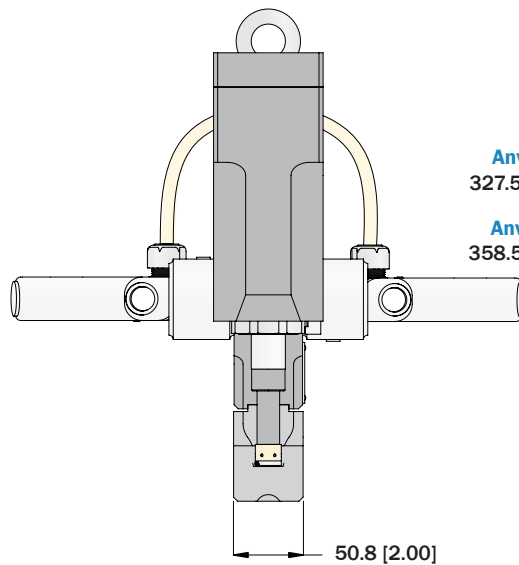

Anvil "A"
327.5 [12.89]

Anvil "B"
358.5 [14.11]

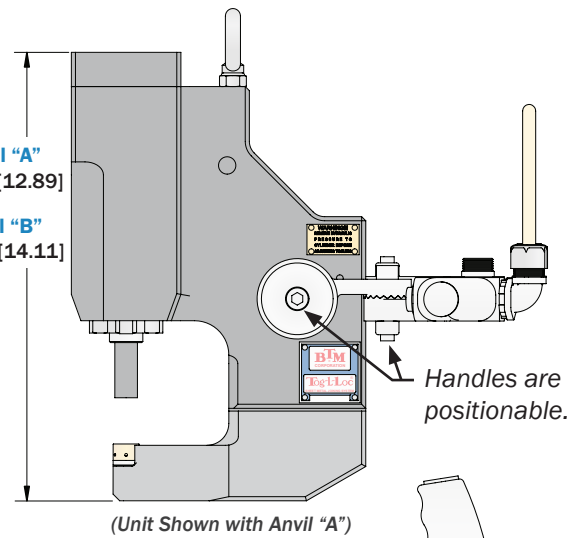

(Unit Shown with Anvil "A")

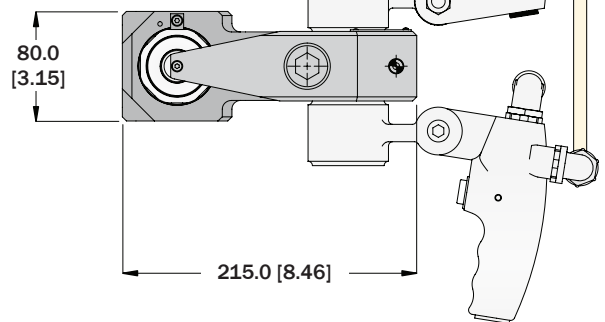

HEAVY DUTY 7006 UNIT ANVILS

ANVIL "A"

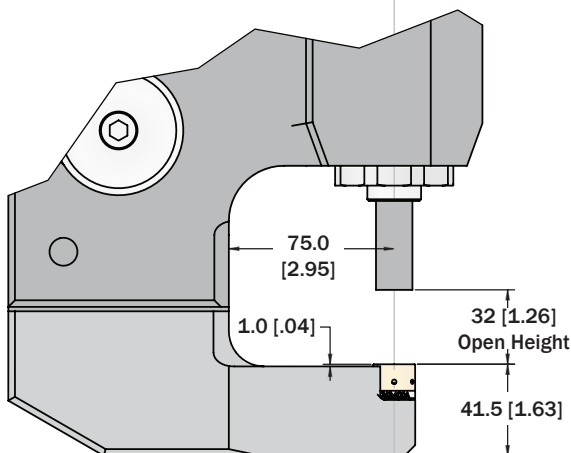

BTM NUMBER	
Heavy Duty 7006 Unit with Anvil "A"	792100A

ANVIL "B"

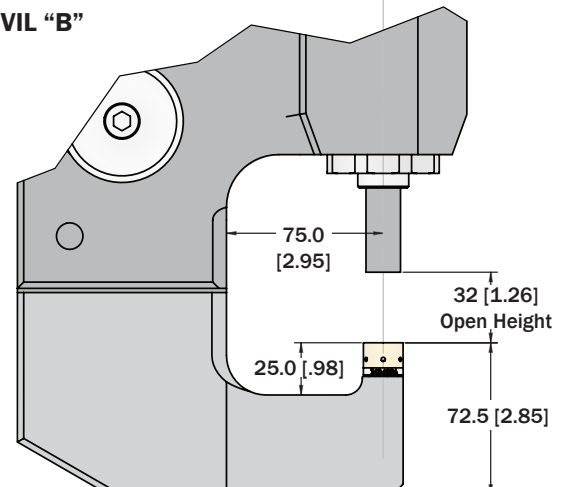

BTM NUMBER	
Heavy Duty 7006 Unit with Anvil "B"	792100B

FULLY ADAPTABLE UNIT

The Fully Adaptable Unit is all about flexibility due to its customizable features.

Joint size, accessibility to the part, throat depth, opening, force requirement, and ergonomics can all be designed to your requirements to make the perfect combination for maximum productivity.



www.btmcomp.com/fully-adaptable-units.html

A FULLY ADAPTABLE UNIT IS BEST WHEN:

- You want a high degree of flexibility and force.
- Your part has complex joining locations.



May use **HydroPak2 Hydraulic Pump**
(Depending on the Unit's Configuration)



(See page 29)

Maximum Combined Material Thickness that can be joined with this unit

4mm [.16"]

Clinch Joint Type

Round or **Geo-Clinch®**

Tool Size(s)

3.0

3.8

4.6

5.5

6.4

TYPICAL APPLICATIONS FOR A FULLY ADAPTABLE UNIT:

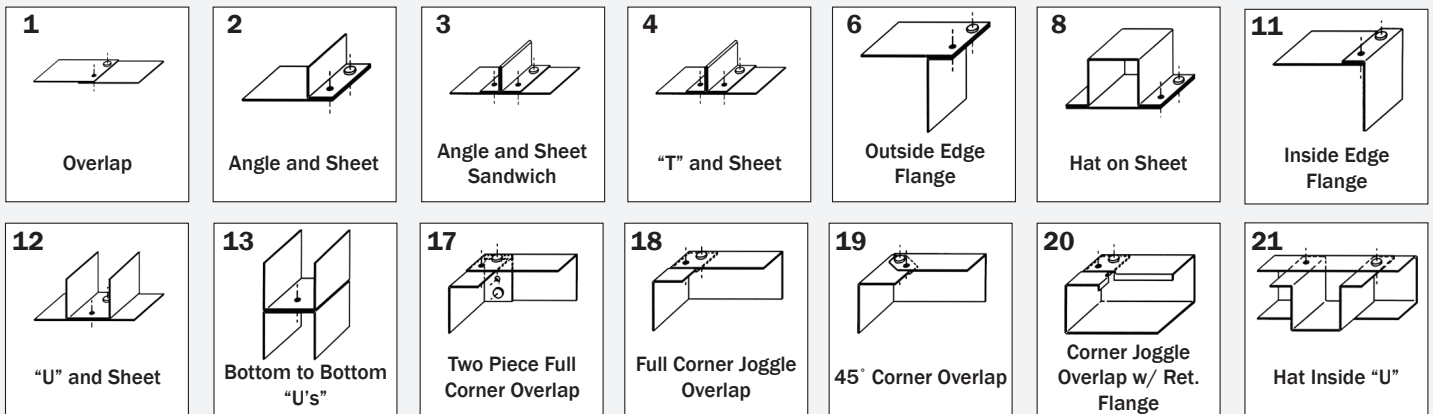

HOW TO ORDER



It is recommended that you [contact a BTM sales engineer](#) prior to purchasing a handheld unit to determine the optimal tooling configuration for your application.

Email info@btm-europe.de to request a quote!

FULLY ADAPTABLE UNIT

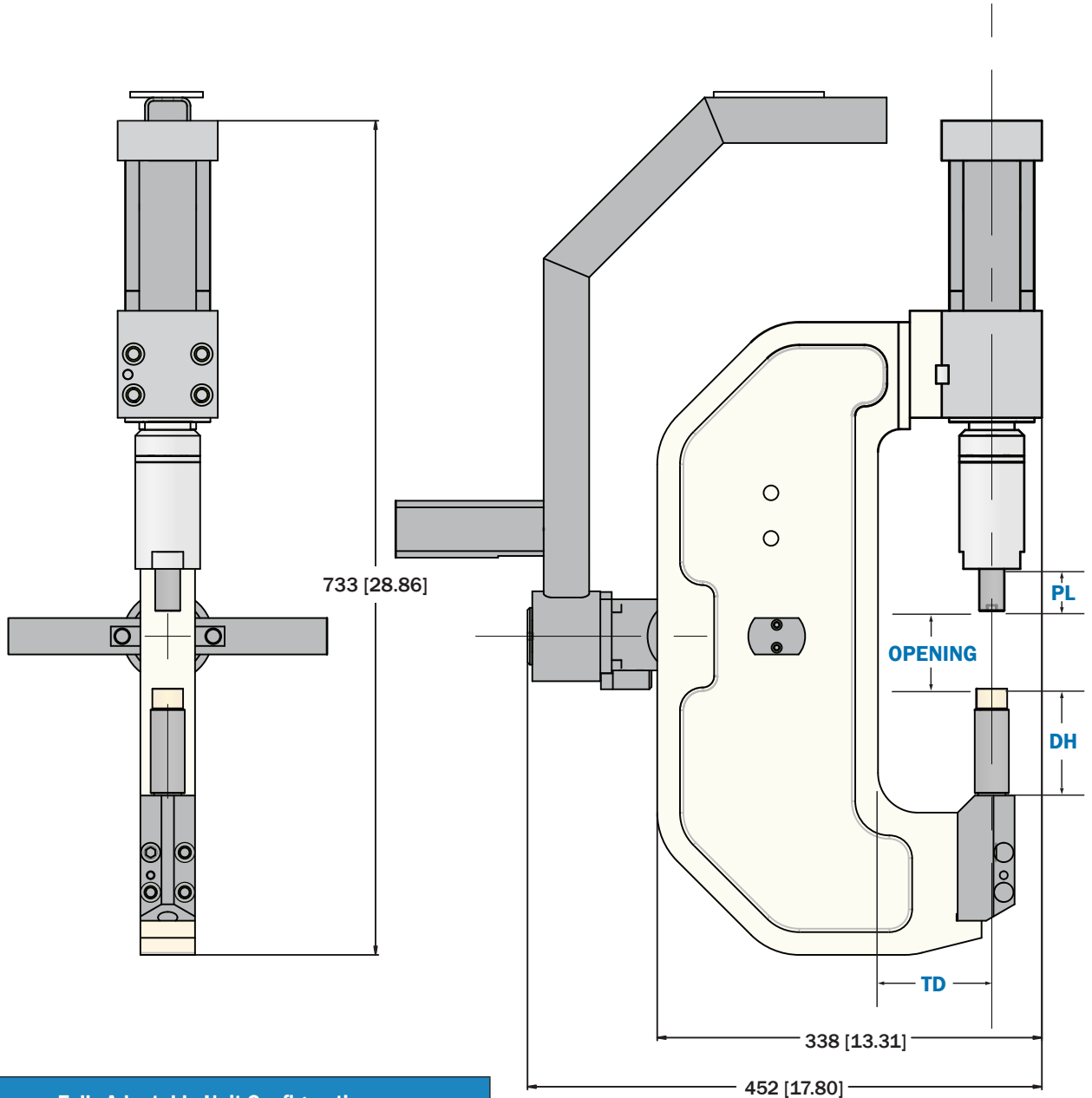

Fully Adaptable Unit Configuration

Throat Depth (TD) = _____

Die Length (DL) = _____

Punch Length (PL) = _____

Opening = _____

Tool Size = _____

(3.0, 3.8, 4.6, 5.5, or 6.4)

*Note: Unit may require a custom Hydraulic Pump.
Contact BTM for more Information.*

Learn more online at:

www.btmcomp.com/fully-adaptable-units.html

or send us an email at info@btm-europe.de

HYDRAULIC PUMP

Power	3 kW
Power Supply	380/400V 3 phase
Maximum Pressure	190 Bar
Working Pressure	160 Bar
Recommended Oil	HLP 32
Weight Without Oil	80 kg
Tank Volume	40 Liter
Control	Siemens Logo
Pump	9 liter single stage

Email info@btm-europe.de to request a quote!

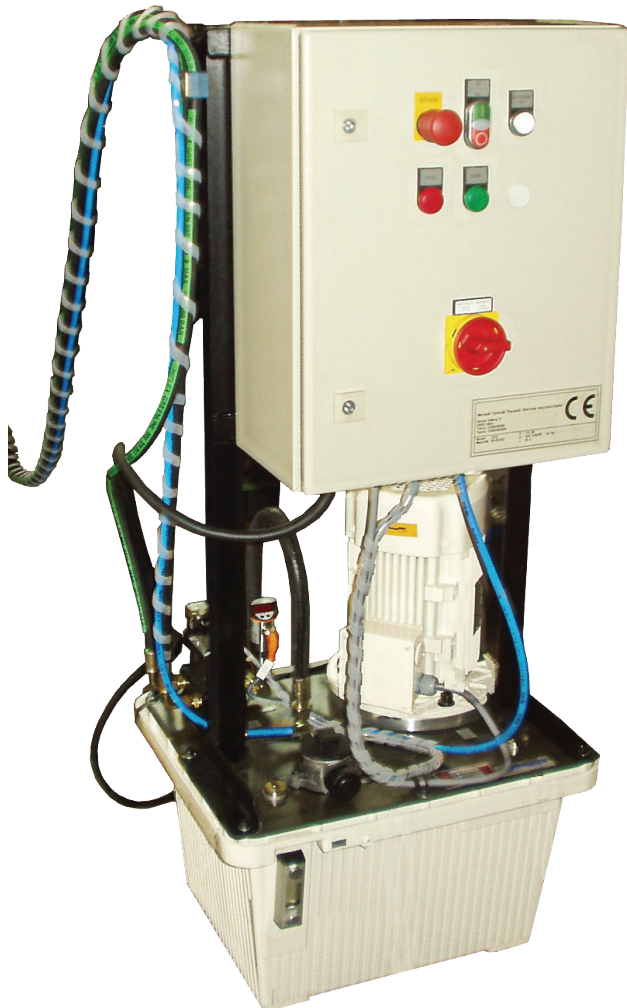

UNIT COMPATIBILITY

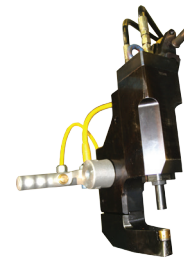

7006
(See page 22)



Heavy Duty 7006
(See page 24)

HYDROPAK2 HYDRAULIC PUMP

The BTM HydroPak 2 Power supply unit is a larger version of the HydroPak 1 being equipped with a 5hp motor, 8 GPM 2 stage pump, 25 gallon oil tank and oil cooler for operation at higher ambient temperatures.

A touch screen PLC provides safe and effective 2 hand, anti-tie down logic control of the clinch unit's trigger switches. The unit will automatically shut off after a period on non-use.

Flow Rate	30.31/min @ 45 BAR [8 GPM @ 650 PSI] 8.31/min @ 172 BAR [2.2 GPM @ 2500 PSI]
Motor Size	5 HP
Electrical Supply	480 VAC 60 HZ single phase 20 amp.
Power Consumption	3800 watts
Maximum Pressure	207 BAR [3000 PSI]
Working Pressure	45/172 BAR [650/2500 PSI]
Tank Capacity	94.6 Liters [25 Gallons]
Weight Without Oil	224 kg [492 lbs]



UNIT COMPATIBILITY



Fully Adaptable Unit
(Depending on its Configuration)
(See page 26)

HOW TO ORDER

Email info@btm-europe.de to request a quote!

HYDROPAK2 BTM NUMBER

3001900A

Hose Assemblies Are Sold Separately. [Contact BTM.](#)

COMPACT BATTERY CLINCH UNIT

The lightweight and easy-to-position Compact Battery Clinch Unit is ideal for low volume sheet metal repair work and/or when utility electricity is not available.

The “C” frame can be rotated relative the trigger for easy selection of an ergonomic operating position.

The stroke is activated by one push button and the return is initiated automatically once a joint has been completed. The advance stroke can be interrupted at any time.

The units are powered by efficient lithium-ion rechargeable batteries but an optional AC power supply cable for all common voltage systems is available.

Up to 50000 clinches can be made between service intervals. **Contact BTM for more information.**



Head rotates 360°



www.btmcomp.com/battery-clinch-units.html

A BATTERY OPERATED UNIT IS BEST WHEN:

- An edge of a part is being joined.
- No access to a power source is available.
- A light-weight and ergonomic tool is desired.
- A high degree of mobility is required.

Power Stroke	16mm [.63"]
Throat Depth	See C-Frames on p. 31 & 33
Trigger Type	Single
Battery Type	18V/1.5Ah Lithium-Ion
Charging Time	Approximately 30 Minutes
Cycle Time	Contact BTM
Unit Weight	Varies with C-Frame
Max. Combined Material Thickness that can be joined with this unit	4mm [.16"]

Clinch Joint Type*	Round		
Tool Size(s)	3.0	3.8	4.6

TYPICAL APPLICATIONS FOR A BATTERY CLINCH UNIT:

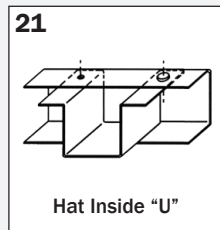
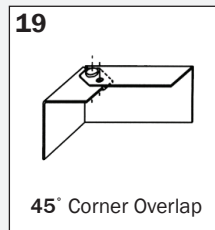
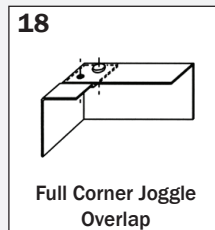
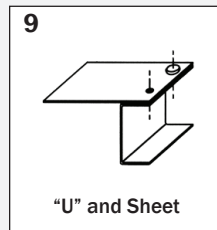
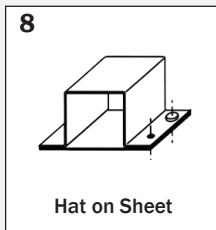
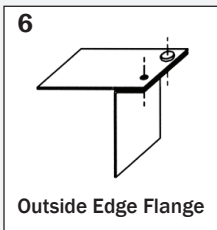

HOW TO ORDER



It is recommended that you [contact a BTM sales engineer](#) prior to purchasing a handheld unit to determine the optimal tooling configuration for your application.

Contact BTM - email: info@btm-europe.de

Each Order Includes:

- Two sets of Clinch Tooling
- One Rechargeable Battery
- One Battery Charger

**COMPACT
BATTERY
CLINCH UNIT**

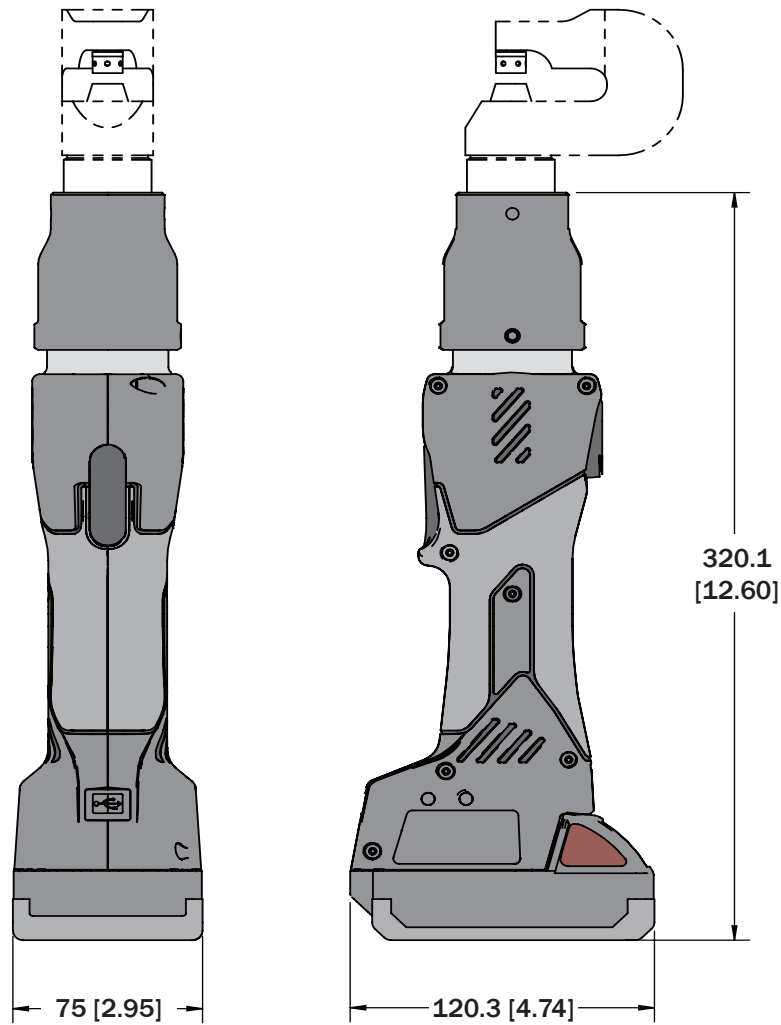

EXAMPLE C-FRAMES

EU1 (01-384-00100)

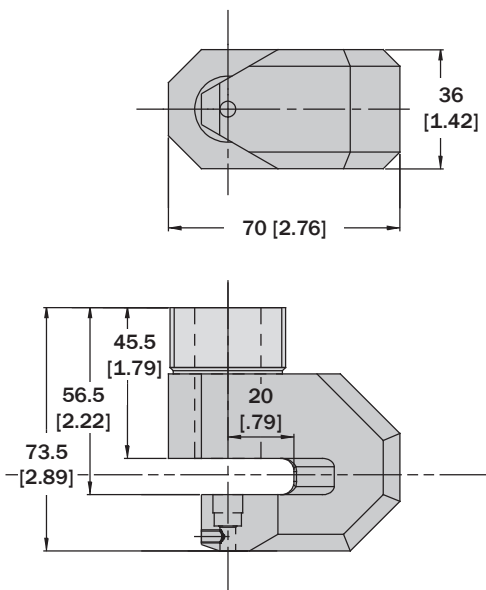

EU2 (01-72-010)

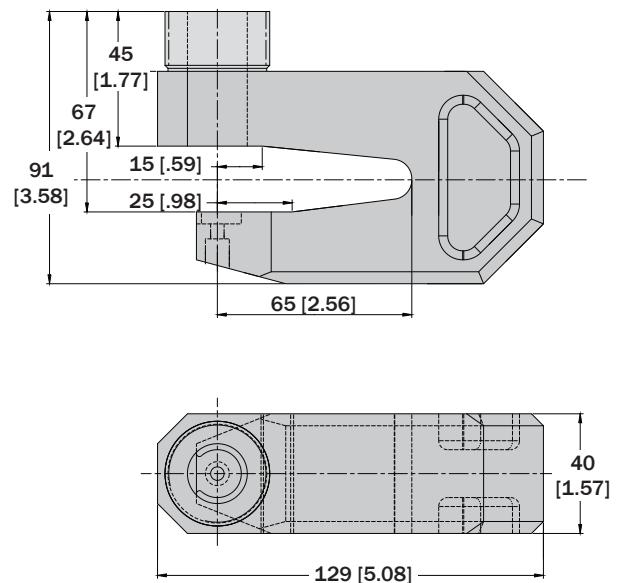

More examples of C-Frames are available (see page 33). **SPECIALS AVAILABLE! CONTACT BTM!**

BATTERY CLINCH UNIT

This Battery Clinch Unit is powerful enough to make 5.5 size Tog-Loc® joints in most common sheet metal thicknesses.

The unit operates by a single push button, is lightweight, ergonomic and has a robust design suited for the construction site.

This Battery Clinch Unit is ideal for low volume sheet metal repair work and/or when utility electricity is not available.

The “C” frame can be rotated relative the trigger for easy selection of an ergonomic operating position.

The units are powered by efficient lithium-ion rechargeable batteries but an optional AC power supply cable for all common voltage systems is available.

Up to 50000 clinches can be made between service intervals. **Contact BTM for more information.**



Head rotates 360° ↗



www.btmcomp.com/battery-clinch-units.html

A BATTERY OPERATED UNIT IS BEST WHEN:

- *An edge of a part is being joined.*
- *No access to a power source is available.*
- *A light-weight and ergonomic tool is desired.*
- *A high degree of mobility is required.*

Power Stroke	10-25mm [.39”-.98”] Adjustable
Throat Depth	Varies per C-Frame
Trigger Type	Single
Battery Type	14.4V/2.6Ah Lithium-Ion
Charging Time	Approximately 45 Minutes
Cycle Time	Varies with Stroke Length
Unit Weight	Varies with C-Frame
Max. Combined Material Thickness that can be joined with this unit	Contact BTM

Clinch Joint Type*	Round			
Tool Size(s)	3.0	3.8	4.6	5.5

TYPICAL APPLICATIONS FOR A BATTERY CLINCH UNIT:

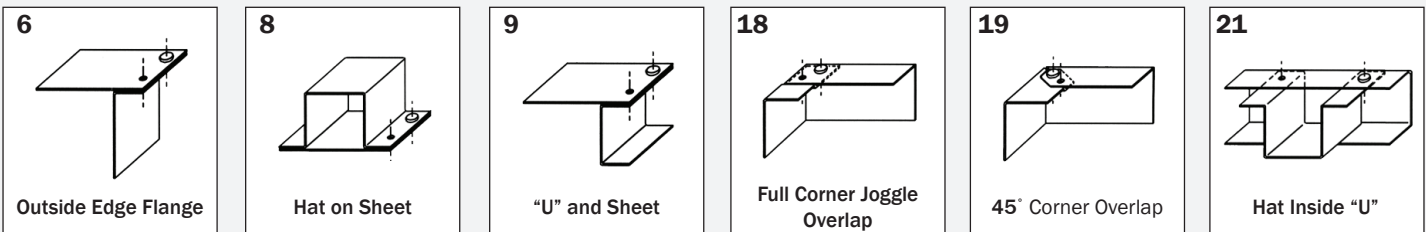

HOW TO ORDER



It is recommended that you [contact a BTM sales engineer](#) prior to purchasing a handheld unit to determine the optimal tooling configuration for your application.

Contact BTM - email: info@btm-europe.de

Each Order Includes:

- Two sets of Clinch Tooling
- One Rechargeable Battery
- One Battery Charger

BATTERY CLINCH UNIT

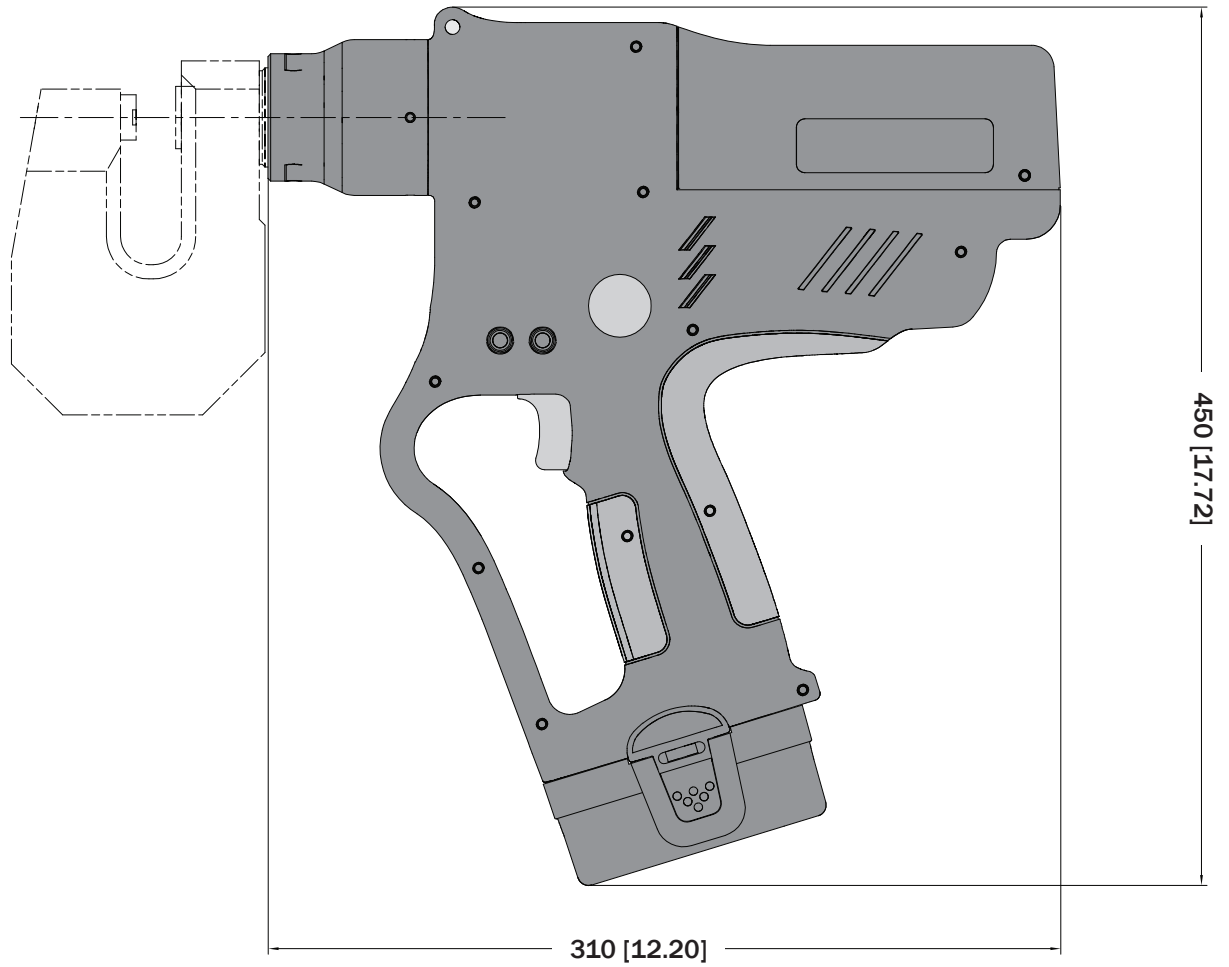

EXAMPLE C-FRAMES

EU3 (01-303-00010)

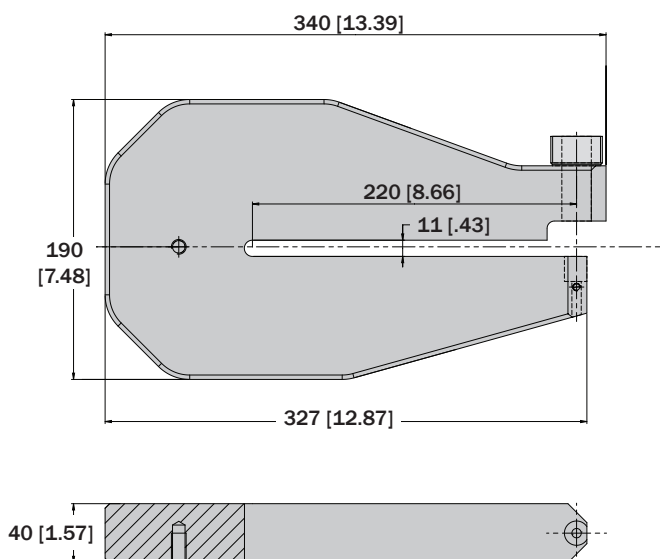

EU4 (EN-11-529)

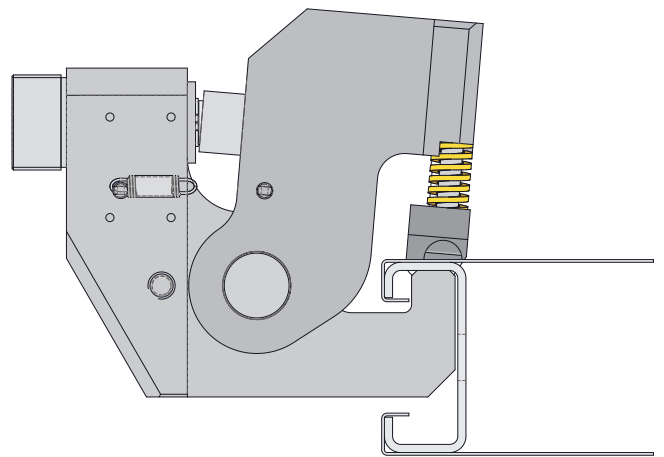

More examples of C-Frames are available (see page 31). **SPECIALS AVAILABLE! CONTACT BTM**

OPTIONAL EQUIPMENT

DUROLOC7 180° ROTATION HANGER

This hanger allows a Duroloc7 Unit to rotate 180° on a single axis.

Email info@btm-europe.de to request a quote!



Unit Compatibility	Weight (without Unit)	BTM NUMBER
Duroloc7 Unit (See page 12)	3.4 kg [7.5 lbs]	PD281500R

DUROLOC7 360° HANGER

This hanger allows a Duroloc7 Unit to rotate a full 360° on a single axis.

Email info@btm-europe.de to request a quote!

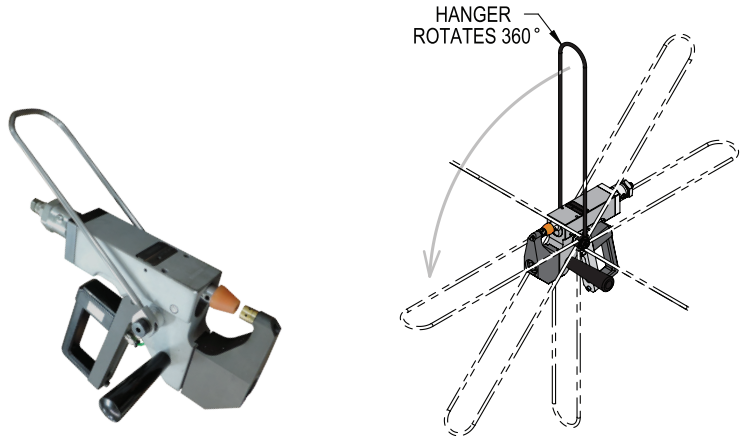

Unit Compatibility	Weight (without Unit)	BTM NUMBER
Duroloc7 Unit (See page 12)	0.37 kg [0.82 lbs]	PD281500J

7006 UNIT 360° GIMBAL MOUNT

This Gimbal Mount allows a 7006 Unit to rotate a full 360° on three axis.

Email info@btm-europe.de to request a quote!

Unit Compatibility	Weight (without Unit)	BTM NUMBER
7006 Units [700600M or 700600N] (See page 22)	3.3 kg [7.2 lbs]	700600G
Heavy Duty 7006 Units [792100A or 792100B] (See page 24)	5.3 kg [11.8 lbs]	792100G

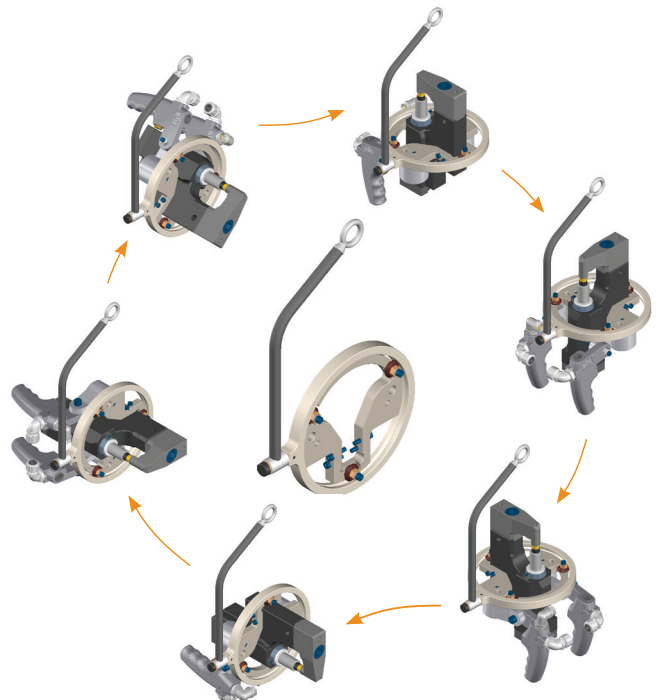

SPRING BALANCERS

A spring-actuated balancer with an external adjustment to quickly and easily set the correct tension. Each balancer includes a mounting hook that rotates 360°.

Email info@btm-europe.de to request a quote!



Picture shows one type of spring balancer. Actual balancer may vary depending on weight range.

Weight Range	BTM NUMBER
2.6-3.8 kg [5.73-8.38 lbs]	052945
3-5 kg [6.6-11 lbs]	052936
4-7 kg [10-15 lbs]	052937
6-10 kg [13.3-22 lbs]	051898
9-14 kg [20-30 lbs]	024049
13-17 kg [29-37 lbs]	024050
20-30 kg [44-66 lbs]	025900
30-45 kg [66-99 lbs]	034426

BTM offers a range of Production Equipment for applying our Clinch tooling.

Unitized "C-Frame" Tooling



BTM's unitized "C-Frame" tooling is a low cost way to utilize the patented Tog-L-Loc[®] sheet metal joining system and is available with a wide range of throat depths. The units are easily mounted, and are ready to install into your brake or stamping press.

Die Sets



Clinch tooling can be inexpensively designed into single or compound motion die set packages.

Hand Held Units



BTM's handheld units are an economical approach to fastening sheet metal assemblies. Pneumatic, Hydraulic, and Self-Contained Units in a variety of styles are available. The units can be set up to join a range of thicknesses.

Special Fixtures



Manually loaded and unloaded dedicated tooling can be built for a single part or a family of parts.

Universal Presses



Universal presses easily adapt to join a variety of parts.

Special Systems



Achieve faster cycle times with automatic part transfer and by combining processes.

Specialized Units



BTM provides pneumatic, hydraulic, air/oil, and electrically driven units with single or dual motions for both stationary and robotic applications.

Find more information online:

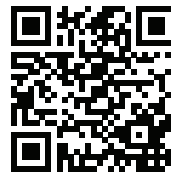

www.btmcomp.com/clinching-equipment.html



For more information, or to see our full line of products, please visit:

WWW.BTM-EUROPE.DE